

# Thermodynamic Analysis of a Modified Two-Stage Trans-Critical CO<sub>2</sub> Refrigeration Cycle with Multi Inter-Cooling System

**A. R. Rahmati\***

Department of Mechanical Engineering,  
University of Kashan, Iran  
E-mail: ar\_rahmati@kashanu.ac.ir  
\*Corresponding author

**A. Gheibi**

Department of Mechanical Engineering,  
University of Kashan, Iran  
E-mail: Aligheibi90@yahoo.com

**Received: 23 May 2017, Revised: 12 June 2017, Accepted: 24 July 2017**

**Abstract:** Performance of a two-stage multi-inter-cooling trans-critical CO<sub>2</sub> refrigeration cycle containing internal heat exchanger, two intercoolers, ejector, and separator, has been analyzed after modification. In the present study, an internal heat exchanger has been included within this cycle for possible improvement in its cooling performance. The impacts of operational parameters such as gas cooler and evaporator temperatures and gas-cooler pressure, on cycle performance have been investigated. Results are validated against those available in the literature. Comparisons of the results show that there is excellent agreement between them. Obtained results showed that modified cycle improved the maximum coefficient of performance ( $COP_{max}$ ), by 20.58% compared to the internal heat exchanger two-stage TRCC cycle and 23.2% compared to multi-inter-cooling two-stage TRCC cycle with ejector expansion device. Also, the total exergy destruction rate of the improved cycle is between its rates of two original cycles.

**Keywords:** Ejector-expansion, Internal heat exchanger, Refrigeration, Two-stage, Transcritical

**Reference:** Rahmati, A. R., Gheibi, A., “Thermodynamic Analysis of a Modified Two-Stage Trans-Critical CO<sub>2</sub> Refrigeration Cycle with Multi Inter-Cooling System”, *Int J of Advanced Design and Manufacturing Technology*, Vol. 10/ No. 3, 2017, pp. 97–104.

**Biographical notes:** **A. R. Rahmati** received his PhD in Mechanical Engineering from Isfahan University of Technology in 2010. He is currently Assistant Professor at the Department of Mechanical Engineering in University of Kashan. His current research interest includes refrigeration cycles and LBM. **A. Gheibi** is PhD student of Mechanical engineering at the University of Kashan. His current researches focus on numerical solution in fluid mechanics and refrigeration cycles.

## 1 INTRODUCTION

Due to global environmental concerns, the usage of natural working fluid is becoming more interesting theme to be discussed. Trans-critical CO<sub>2</sub> cycle is recently considered as one of the most influential refrigerant for its characteristics such as non-flammability and non-toxicity despite the drawback of high working pressure. For years, authors studied the application of trans-critical CO<sub>2</sub> cycle for refrigeration. The American Alexander Twining was the first researcher who suggested the use of carbon dioxide as a refrigerant for vapor compression system in his study in 1850. During the expansion of a refrigerant in a throttling process, much friction heat is dissipated to the refrigerant due to the large kinetic energy increases as the refrigerant pressure decreases. In a CO<sub>2</sub> trans-critical vapor compression refrigeration cycle, the throttling loss is greater than with conventional refrigerants owing to the higher pressure change during the expansion. Various devices and techniques have been exploited in order to reduce this loss like ejector that is a type of pump that uses the venture effect of a converging-diverging nozzle to convert the pressure energy of a motive fluid to velocity energy which creates a low pressure zone that draws in and entrains a suction fluid. After passing through the throat of the ejector, the mixed fluid expands and the velocity is reduced which results in recompressing the mixed fluids by converting velocity energy back into pressure energy.

Denso Corporation [1] stated that the coefficient of performance of a CO<sub>2</sub> trans-critical automotive air conditioning with an ejector was 25% better than the cooling COP of a convention vapor compression refrigeration cycle in their experiments. Kornhauser [2] investigated the thermodynamic performance of the ejector expansion refrigeration cycle using R-12 as a refrigerant. He found that a theoretical COP could be improved up to 21% over the standard cycle under ideal conditions and constant mixing pressure in the ejector. Domanski [3] realized that ejector efficiency significantly influences the cooling COP of the ejector expansion refrigeration cycle. Fan and Wu [4] investigated the modified ejector expansion refrigeration cycle with two heat sources. Disawas and Wongwises [5] experimentally investigated the performance of the ejector expansion refrigeration cycle without the expansion valve upstream of the evaporator. Their result showed an improved cooling COP at low heat sink temperatures relative to the convention cycle with R-13a as the refrigerant. Deng et al [6] describe a theoretical analysis of a trans-critical CO<sub>2</sub> ejector expansion refrigeration cycle, which uses an ejector as the main expansion device instead of an

expansion valve. For the working conditions studied in their study the maximum cooling COP is up to 18.6% better than the internal heat exchanger cycle and 22% better than the conventional vapor compression refrigeration cycle. Yari [7] proposed a new two-stage configuration of ejector-expansion trans-critical CO<sub>2</sub> refrigeration cycle. He uses an internal heat exchanger and inter-cooler to enhance the performance of the cycle. He showed that the COP and second law efficiency values of the new cycle are on average 8.6% and 8.15% higher than that of the conventional ejector-vapor compression refrigeration cycle with R<sub>12</sub> as refrigerant. Eskandari and Yavari [8] investigated a new two-stage multi inter-cooling trans-critical CO<sub>2</sub> refrigeration cycle. At their study, the first intercooler cooled with external coolant and the second one with cycle refrigerant. They found that the maximum COP value of the new cycle in the surveyed high-side pressure interval is 15.3% and 19.6% higher than CERC and IHEEC the internal heat exchanger ejector refrigeration cycle respectively. In this paper, in order to improve the COP of the cycle we present a modified two-stage trans-critical CO<sub>2</sub> refrigeration cycle with an ejector, internal heat exchanger and two intercoolers. The new idea in the modified cycle is that first intercooler is cooled with external coolant and second one is cooled with cycle refrigerant, which is a portion of saturated vapor coming out of vapor-liquid separator. Also, an internal heat exchanger is added to the cycle. The performance of the new cycle was compared with the internal heat exchanger two-stage TRCC cycle (IHEC) and multi-inter-cooling two-stage TRCC cycle with ejector expansion device (MIERC) that are illustrated in Fig. 1 and Fig. 2, respectively.

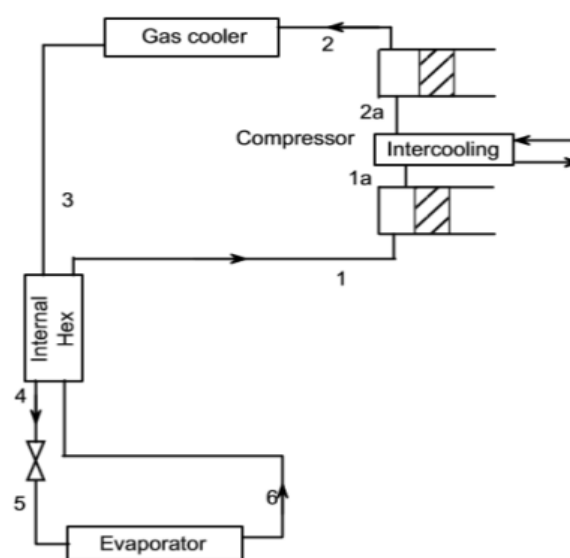

Fig. 1 Schematic of internal heat exchanger two-stage TRCC cycle (IHEC)

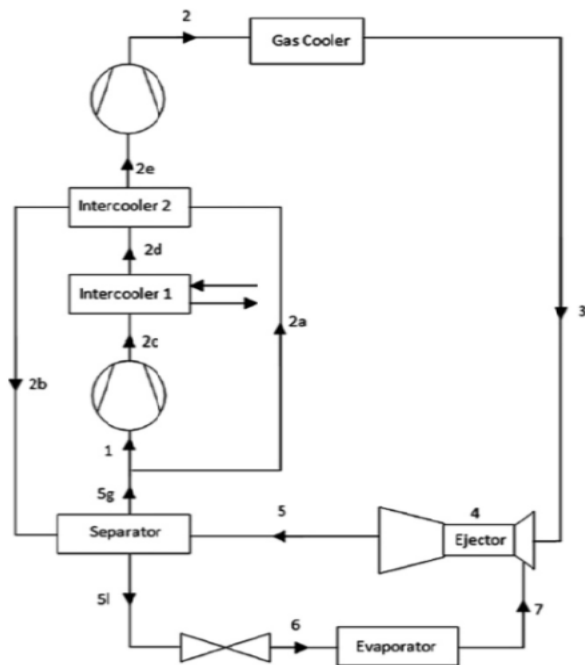

Fig. 2 Schematic of multi-inter-cooling two-stage TRCC cycle with ejector expansion device (MIERC)

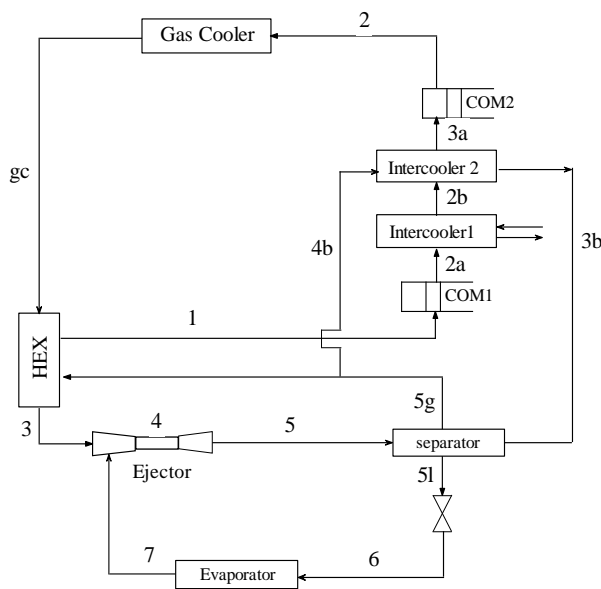

Fig. 3 Schematic of new multi-inter-cooling two-stage TRCC cycle with ejector and internal heat exchanger

## 2 CYCLES DEFINATION

The basic elements of a paper are listed below. In Figs. 3 and 4, a schematic and the corresponding P-h diagram of the new two-stage multi-inter-cooling trans-critical CO<sub>2</sub> refrigeration cycle with ejector and internal

heat exchanger are shown. In the new cycle all procedures were performed according to similar procedures in reference No. 7. The difference is that the saturated vapor outlet from separator is divided in two streams; one of them goes to the internal heat exchanger and the other one enters the second intercooler with mass flow rate (x). The cooling vapor fed to the intercooler, returns to separator.

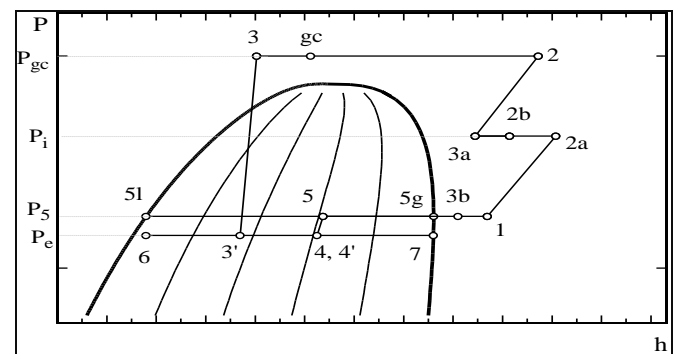

Fig. 4 P-h diagram of new multi-inter-cooling two-stage TRCC cycle with ejector and internal heat exchanger

## 3 THERMODYNAMIC ANALYSIS

### 3.1. Energy analysis

The following assumptions were taken in modeling the system.

- (1) The systems are simulated under steady state conditions.
- (2) The pressure losses in all pipes and heat exchangers are negligible.
- (3) Adiabatic compressor and ejector,
- (4) The refrigerant leaving evaporator is in saturated vapor state.
- (5) Kinetic energies of the refrigerant at the ejector inlet and outlet are negligible.
- (6) The flow inside the ejector is one-dimensional.
- (7) The mixture pressure in the ejector is equal to the evaporator pressure.
- (8) The cooling flow rate at intercooler (x) is set to  $0.4 \dot{m}_{5g}$ ,
- (9) The temperature of the cooling flow at the second intercooler increases 5°C.

The mass flow rate inside the ejector is set to unite and the rate of cooling flow in intercooler is equal to x. From this consideration, we can conclude that flow rate inside gas cooler and compressors is  $(\dot{m}_{5g} - x)$  and outlet flow rate from ejector is (1-x). The basic equations obtained from the conservation law for energy are written as follows.

**Compressors:**

The compressor first stage power consumption per unit mixture mass flow rate is,

$$w_{c1} = (h_{2a} - h_1)(\dot{m}_{5g} - x) \quad (1)$$

The adiabatic compressor 1 efficiency is [9],

$$\eta_{c1} = 1.003 - 0.121\left(\frac{P_1}{P_l}\right) \quad (2)$$

$$\eta_{c1} = \frac{h_{2as} - h_1}{h_{2a} - h_1} \quad (3)$$

The compressor second stage power consumption per unit mixture mass flow rate is,

$$w_{c2} = (h_2 - h_{3a})(\dot{m}_{5g} - x) \quad (4)$$

The adiabatic compressor 2 efficiency is [9],

$$\eta_{c2} = 1.003 - 0.121\left(\frac{P_2}{P_l}\right) \quad (5)$$

$$\eta_{c1} = \frac{h_{2s} - h_{3a}}{h_2 - h_{3a}} \quad (6)$$

Intercooler,

The optimum intermediate pressure is almost equal to the geometric mean of gas cooler and evaporator pressure:

$$P_l = P_1 P_2 \quad (7)$$

It is assumed that saturated vapor flow is superheated by 5°C within the inter-cooler [10]. Therefore;

$$T_{3b} = T_5 + 5 \quad (8)$$

Applying the first law of thermodynamics for second intercooler gives,

$$(\dot{m}_{5g} - x)(h_{2b} - h_{3a}) = x(h_{3b} - h_{5g}) \quad (9)$$

**Internal heat exchanger:**

The energy balance equation for the internal heat exchanger is,

$$(h_{gc} - h_3) = (h_1 - h_{5g}) \quad (10)$$

The effectiveness of the internal heat exchanger is [11],

$$\mathcal{E}_{HEX} = \frac{h_{gc} - h_1}{h_{5g} - h_1} \quad (11)$$

**Ejector:**

The motive stream enters the ejector and expands to evaporator pressure  $P_e$  with a nozzle efficiency defined as,

$$\eta_n = \frac{h_3 - h_{3'}}{h_3 - h_{3's}} \quad (12)$$

The energy balance between state (3) and (3') is,

$$h_3 - h_{3'} = \frac{u_{3'}^2}{2} \quad (13)$$

The following equation can be written from the momentum conservation in mixing section,

$$\left(1 + \frac{\dot{m}_{sl}}{\dot{m}_{5g} - x}\right)u_4 = u_{3'} \quad (14)$$

The mixing efficiency is given as [12],

$$\eta_m = \frac{u_{4'}^2}{u_4^2} \quad (15)$$

Where,  $u_{4'}$  is the corrected form of  $u_4$ , in order to account for mixing section losses. The energy balance equation between state (4) and (5) is,

$$h_5 - h_4 = \frac{u_{4'}^2}{2} \quad (16)$$

The energy balance for the ejector reveals that,

$$(1-x)h_5 = (\dot{m}_{5g} - x)h_3 + (\dot{m}_{sl})h_7 \quad (17)$$

The refrigerant mixture recovers pressure in the ejector diffuser with a given efficiency of,

$$\eta_d = \frac{h_{4s} - h_4}{h_5 - h_4} \quad (18)$$

**Separator:**

The conservation law of energy for separator is expressed as,

$$xh_{3b} + (1-x)h_5 = (\dot{m}_{5g})h_{5g} + (\dot{m}_{sl})h_{5l} \quad (19)$$

Expansion valve,

$$h_{5l} = h_6 \tag{20}$$

**Evaporator:**

The cooling capacity per unit mixture mass flow rate is,

$$q_e = (h_7 - h_6)\dot{m}_{5l} \tag{21}$$

The system performance is evaluated by coefficient of performance COP, which is the ratio of the cooling capacity to the power absorbed by compressors,

$$COP = \frac{q_e}{w_{c1} + w_{c2}} \tag{22}$$

**3.2. Exergy analysis**

Entropy generation rate for a fixed control volume is given by the following equation [13].

$$\dot{s}_{gen} = \sum \dot{m}_o s_o - \sum \dot{m}_i s_i - \sum \frac{\dot{Q}_k}{T_k} \tag{23}$$

The exergy destruction rate can be evaluated as [14].

$$I = T_0 s_{gen} \tag{24}$$

Based on the above analysis, a steady state simulation program for new two-stage multi-inter-cooling trans-critical CO<sub>2</sub> refrigeration cycle with ejector and internal heat exchanger was developed.

**Table 1** Input parameters used in simulation

Parameters	Value
$T_{amb}$	27 °C
$T_e$	-30 to 5 °C
$T_{gc}$	35-55 °C
$T_0$	300K
$T_r$	$(T_e + 5)K$
$P_{gc}$	75-140 bar
$\epsilon_{HEX}$	80%
$\eta_d$	80%
$\eta_m$	95%
$\eta_n$	80%

Table 1, summarizes the basic assumptions and input parameters of the system simulation and analysis. We consider the working conditions of the present cycle similar to the cycle which was studied by Yari [7]. It should also be noted that in multi-inter cooling TRCC cycle [8], the cooling flow rate at second inter cooler is set 0.3 kg/s but in this study, it's rate is intended 40% of outlet saturated vapor from separator. Note that the mass flow rate of outlet saturated vapor from separator change with changing the parameters of the cycle.

**4 RESULTS AND DISCUSSION**

The validation of the present numerical model is done with the theoretical results for two-stage trans-critical CO<sub>2</sub> refrigeration cycle with ejector and internal heat exchanger [7]. As seen from Fig. 5, there is a good agreement between the two groups of results.

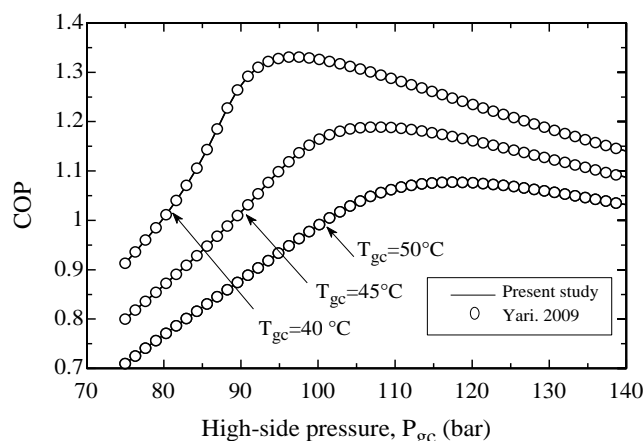

**Fig. 5** Comparison of the present simulation result with the Yari [7] Results.

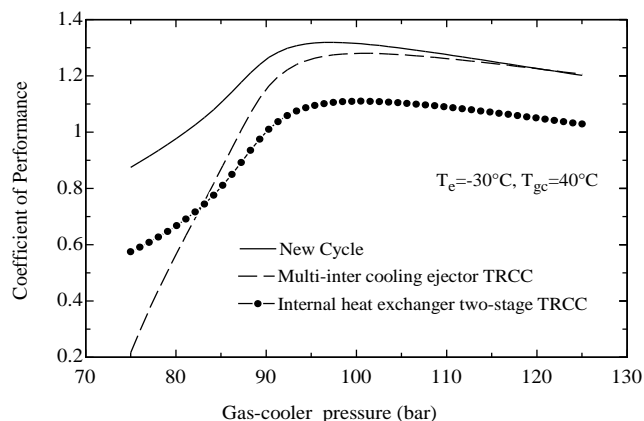

**Fig. 6** The COP value of three cycles versus gas cooler pressure

Figure 6 shows the change of COP value of the three cycles versus the high-side pressure at a given evaporator and gas cooler outlet temperatures. Each cycle has an optimum high-side pressure corresponding to a maximum COP value. Also, as shown in this figure the modified cycle improved the maximum coefficient of performance,  $COP_{max}$ , by 20.58% compared to the internal heat exchanger two-stage TRCC cycle and 23.2% compared to multi-inter-cooling two-stage TRCC cycle with ejector expansion device.

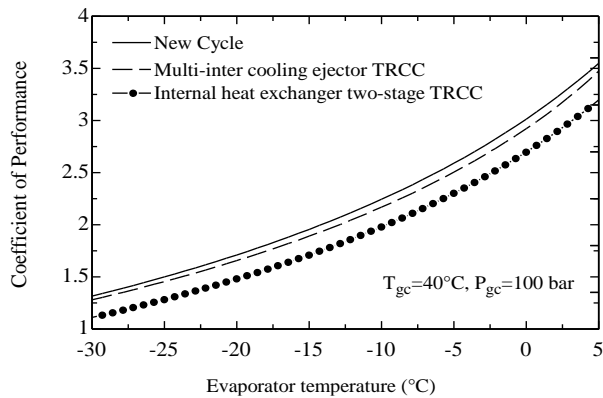

Fig. 7 The COP value of three cycles versus evaporator outlet temperature

Figure 7 Shows the variation of the COP value of three cycles with evaporator temperature at a given high-side pressure and an evaporator outlet temperature. As the evaporative temperature increases the COP increases too. The reason for increasing COP is that by increasing the evaporative temperature as it can be observed from Fig. 8., both the cooling capacity and compressor power decrease. But the rate of reduction of the compressor work is higher, (For example as the evaporator outlet temperature increases from -25°C to -15°C cooling capacity decreases about 3kj/kg while compressor power or the actual work of the cycle decreases about 14kj/kg). Thus, the overall result will be the increasing in the COP.

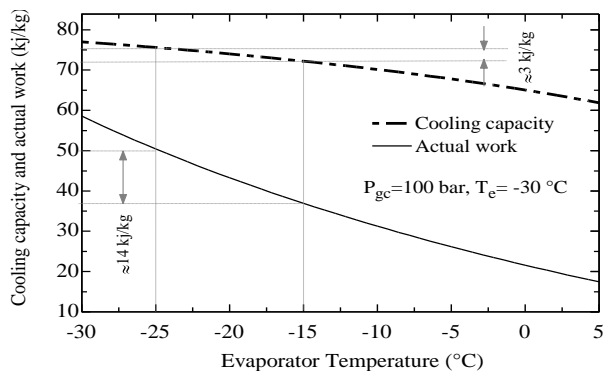

Fig. 8 The cooling capacity and actual work of the cycle value of the new cycle versus evaporator outlet temperature

The variation of the COP with the gas cooler pressure of the new cycle for different evaporator outlet temperatures is shown in Fig. 9. As can be seen for each case there is an optimum high-side pressure (94 bar) corresponding to a maximum COP value and also COP value increases with increasing the evaporator outlet temperature.

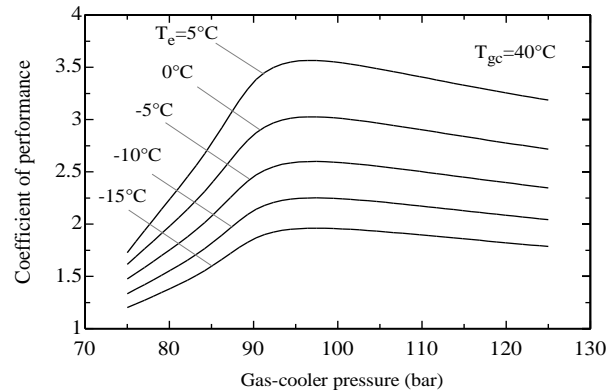

Fig. 9 The COP value of the new cycle versus gas cooler pressure under different evaporator outlet temperature

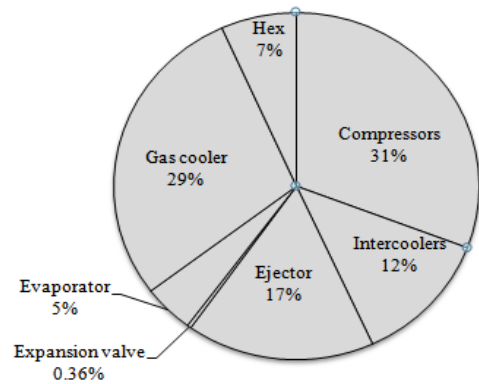
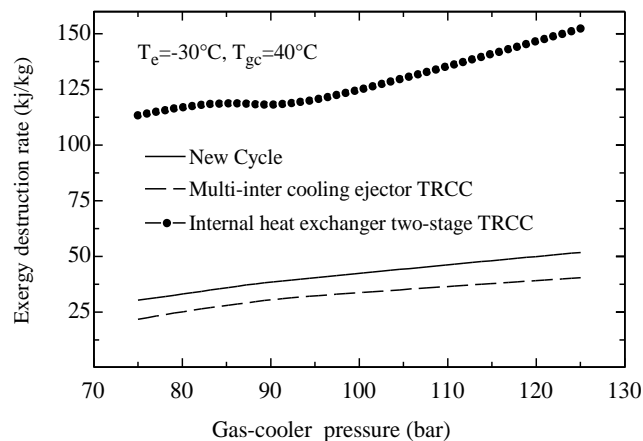

Fig. 10 Exergy destruction rate in each component of the new cycle

Figure 10, shows the exergy destruction rate in each component of the new cycle at a given evaporator and gas cooler outlet temperature and a high-side pressure. Also it is found that the highest exergy destruction rate in the new cycle, occurs in the compressors, about 31% of the total of it.

Figure 11 shows the variation of the total exergy destruction rate of the three cycles versus the gas cooler pressure. This figure surprisingly shows that the total exergy destruction rate of the improved cycle is between the total exergy destruction rates of two original cycles. Adding an internal heat exchanger to the multi-inter-cooling two-stage TRCC cycle increases the refrigerant temperature at the first compressor inlet. It imposes higher heat load to the compression process

and consequently increases exergy destruction rate in the components of compression process. Internal heat exchanger causes excess exergy destruction by itself. Nevertheless, internal heat exchanger decreases the refrigerant temperature at the inlet of expansion system. Hence, it is expected to decrease the exergy destruction rate within the components of expansion system.



**Fig. 11** Exergy destruction rate value of three cycles versus gas cooler pressure

## 5 CONCLUSION

Performance of the new two-stage trans-critical CO<sub>2</sub> refrigeration cycle with ejector was discussed theoretically based on the first and second laws of thermodynamics in this paper. In addition, the results of the new cycle performance were compared with the internal heat exchanger two-stage TRCC cycle and multi-inter-cooling two-stage TRCC cycle with ejector expansion device. The main conclusions from this study are as follows:

1. It is observed that the performance of the new cycle can be significantly improved in all cases that studied the effect of evaporator and gas cooler outlet temperature and high-side pressure on COP.
2. In a high-side pressure, the COP value of the cycles increases with increasing the evaporator temperature.
3. For each evaporator and gas cooler outlet temperature, there is an optimum high-side pressure and mass rate of the saturated vapor from separator corresponding to a maximum COP value.
4. The highest exergy destruction rate in the new cycle occurs in the compressors, about 31% of the total of it.
5. Although internal heat exchanger can improve COP of the cycle at this range of gas cooler pressure, it increases the total exergy destruction rate compared to multi-inter-cooling two-stage TRCC cycle at the same time.

## Nomenclature

h	Specific enthalpy (Kj/Kg)
I	Exergy destruction rate (Kj/Kg)
m	Mass flow rate (Kg/s)
P	Pressure (bar)
q	Specific heat transfer rate (Kj/Kg)
s	Specific entropy (Kj/Kg-K)
T	Temperature (°C)
u	Velocity (m/s)
w	Specific work (Kj/Kg)
x	Mass flow rate of cooling stream in intercooler (Kg/s)

## Symbols

$\eta$	Efficiency (%)
$\varepsilon$	Intercooler effectiveness (%)

## Subscriptions

0	Reference environment
1,2,2a,...	Cycle locations
c	Compressor
d	Diffuser
e	Evaporator
ej	Ejector
ev	Expansion valve
g	Saturated vapor
gc	Gas cooler
gen	Generation
I	Intermediate
IC	Intercooler
L	Saturated liquid
mix	Mixing
n	Nozzle
r	Refrigerated object
rev	Reversible process
s	Isentropic process
t	Total

## REFERENCES

- [1] Yuhala, H., Wang, J., Denso Corporation, "Private Communication", Tsinghua in Beijing, China, 2004.
- [2] Kornhauser, A. A., "The use of an Ejector as a Refrigerant Expander", Proceedings of the 1990 USNC/IIR-Purdue Refrigeration Conference, 1990, pp. 10-19.
- [3] Domanski, P. A., "Theoretical Evaluation of Vapor Compression Cycle with a Liquid-Line/Suction-Line Heat Exchanger, Economizer, and Ejector", National Institute of Standards and Technology, March 1995, pp. 134-145.
- [4] Wu, J. T., Liu, Z. G., Guo, H., and Fu, Q. S., "Thermodynamic Analysis of a New Kind Vapor-Compression/Ejection Refrigeration Cycle", Fluid Machinery No. 28, 2000, pp. 47-47.

- [5] Disawas, S., Wongwises, S., “Experimental Investigation on the Performance of the Refrigeration Cycle using a Two-phase Ejector as an Expansion Device”, *International Journal of Refrigeration*, 2004, pp. 587–594.
- [6] Deng, J. Q., Jiang, P. X., Lu, T., and Lu, W., “Particular Characteristics of Trans-critical CO<sub>2</sub> Refrigeration Cycle with an Ejector”, *Applied Thermal Engineering*, No. 27, 2007, pp. 381–388.
- [7] Yari, M., “Performance Analysis and Optimization of a New Two-stage Ejector Expansion Trans-critical CO<sub>2</sub> Refrigeration Cycle”, *International Journal of Therm. Sci.* No. 48, 2007, pp. 1997-2005.
- [8] Eskandari, F., Yavari, M. A., “Performance of a New Two-stage Multi-inter-cooling Trans-critical CO<sub>2</sub> Ejector Refrigeration Cycle”, *Applied Thermal Engineering*, No. 40, 2012, pp. 202–209.
- [9] Liao, S. M., Zhao, T. S., and Jakobsen, A., “Correlation of Optimal Heat Rejection Pressures in Trans-critical Carbon Dioxide Cycles”, *Applied Thermal Engineering*, No. 20, 2012, pp. 831–841.
- [10] Goodarzi, M., Gheibi, A., “Performance Analysis of a Modified trans-critical CO<sub>2</sub> Refrigeration Cycle”, *Applied Thermal Engineering*, 2015, pp. 1118-1125.
- [11] Yari, M., Sirousazar, M., “Cycle Improvements to Ejector-expansion Trans-critical CO<sub>2</sub> Two-stage Refrigeration Cycle”, *International Journal of Energy Research*, No. 32, 2013.
- [12] Liao, S. M., Zhao, T. S., and Jakobsen, A., “Correlation of Optimal Heat Rejection Pressures in Trans-critical Carbon Dioxide Cycles”, *Applied Thermal Engineering*, No. 20, 2000, pp. 831–841.
- [13] Cengel, Y. A., Boiles, M. A., “*Thermodynamics: An Engineering Approach*”, Mc Graw-Hill, Inc., 6nd ed., 2007,
- [14] Bejan, A. (ed), “*Thermal Design and Optimization*”, John Wiley and Sons, Inc., New York, NY, 1997.