

# New Power Losses Allocation Method Based on the Decomposition of the Network Matrix and the Voltage Regulation at Network Nodes

Roger Tchuidjan, Oumarou Hamandjoda, Gérard Mbobda, Moses Tabe and Henguert Otto

Power Unit – Energetics and Automation Laboratory  
National Advanced School of Engineering – University of Yaounde I – Cameroon  
tchuir@yahoo.fr

Received August 2013

Revised September 2013

Accepted November 2013

## ABSTRACT:

In the modern context of electricity market deregulation, the price of the kilowatt-hour must take both power injections and withdrawals of the multiple market participants into consideration, as well as their actual grid usage. The responsibility for causing transmission losses and voltage drops therefore, needs to be fairly attributed. While grid power injections and withdrawals are unequivocally attributed, it remains to date impossibly to naturally share responsibility for transmission losses. Relevant literature proposes a variety of methods. This paper proposes a new method for allocating transmission losses to market participants by using the network. The overall grid losses are obtained from summing the difference between injected and withdrawn power for all nodes. A set of allocation factors derived from the electrical distance between concerned buses and their voltage levels that is used to attribute active power loss to each bus, after the losses which are arising from the mutual influencing between buses has been calculated. This method focuses on bus bar current injections and it assumes which there is a hypothetical power flow between nodes. For mutual influencing, one of the bus bars is considered a generator and the other is a load. A reference bus voltage is set and then the load side is penalized depending on how far its own voltage is lower than that reference value. Results from a sample network are compared to those of previous methods.

**KEYWORDS:** loss allocation, admittance matrix, electricity market, allocation factors, bus mutual influencing, auxiliary services.

## 1. INTRODUCTION

The aim of power loss allocation in a deregulated market environment is to establish the financial responsibilities of each market participant in the power transmission losses, based on actual grid usage. In open electricity markets, power distributors declare their demands and their needs which are divided among different production units by the independent system operator (ISO). These units receive an order-one day in advance to generate a specified quantity of energy at a pre-determined price. This regulation method does not take the network layout into consideration, and such as, equally ignores the transmission losses [1], [2], [14].

During power supply, a certain quantity of energy  $X$  is measured at the consumer's end, while a different quantity  $Y$ , which is higher than  $X$  because of the transmission losses, is measured emanating from the producer's units. Because these losses increase the production and plant maintenance costs, the producers simply bill these losses to consumers by increasing the

cost of the kilowatt-hour. The question, which truly is the root cause of these losses and, as such, should bear the responsibility for the appearance of these losses, becomes justified. In the Cameroonian vertically integrated electricity system, the costs associated with these transmission losses are simply rolled over to consumers, making the electricity unit price volatile and arbitrary. However, since the consumer does not choose the network topology and the characteristics of the transaction power-flow path, it becomes important to seek better and fairer ways of sharing the costs due to transmission losses. Undoubtedly, both producers and consumers are at the origin of all transaction losses. Unfortunately, neither losses are directly proportional to the amount of power transacted, nor is electrical power a stamped resource that can be traced back to a specific generating entity. It is consequently impossible to associate responsibilities in energy transits and line losses to specific producers and consumers in an exact scientific manner. Besides, even if linearization techniques are resorted to, they often depend on the

linearization zone. In addition, the crossed term of the quadratic function means that some loss components must be allocated simultaneously to both suppliers and consumers. This is not possible [ $2xy$  of  $(x+y)^2$ ] [3], [4]. To solve this problem, numerous methods have been proposed in the relevant literature. These methods can be grouped into the following five main categories: pro rata, proportional, incremental, circuit-based, and other interesting approaches for bilateral exchanges.

Pro-rata methods are the most used. Here, power loss allocation is based on the amount of power, which is supplied or consumed. Another variant is based on current injections in each network bus. These methods do not take the location of market participants within the network into account. So, market participants who are far away from production or consumption centres are favoured, to the detriment of those who are nearer to them. In addition, these methods start by setting the percentage of the losses to allocate to each group, e.g. 50 % to consumers and 50 % to producers, before any further breakdown. They are used in mainland Spain, England and Wales [1], [2], [4].

The proportional sharing method consists of allocating power losses to market participants from the power flow solution. Losses are hence determined based on this principle using a linear sharing procedure. To allocate losses to a load, the author assumes that: "losses associated with every line whose flow enters a given bus are transferred to the lines whose flows leave the bus (or demand in that bus) proportionally to the flows of those lines (the flows of which leave the bus)." From this perspective, it is obvious that the losses are being shared only among loads. It should be therefore, possible to share losses only among generators too. In order to allocate losses to every market participant in the final analysis, it becomes necessary to first fix the loss percentage to be attributed to the generating side and that to be attributed to the load side [4], [5].

Interest in incremental methods is increasing. They are based on the determination of Incremental Transmission Loss factors (ITL factors). These methods can give negative allocations, and the slack bus has no penalty. Furthermore, normalization is useful to make a correspondence between the total effective network loss and the sum of the losses calculated thanks to ITL factors. These methods are already in use in Norway, but still under study in Spain and the United Kingdom [4], [6], [11].

Methods based on the network impedance and admittance matrices permission, when writing out the different bus losses from the power flow equations, the regrouping of terms related to the specific bus used in the mathematical formulation of the problem [13].

In the approaches which use bilateral exchange, losses are attributed to energy exchange among buses by diverse means [7], [12].

Whichever of the above methods is considered, a certain degree of arbitrariness is involved, ranging from the percentage sharing of losses to generation and consumption to the attribution of zero loss to a node. Because of the non-linearity of the power flow problem, and the nature of the commodity "electricity" mentioned earlier, it is difficult to affirm with certainty the superiority of one loss allocation method with respect to the others. However, in order to be attractive and worthy of any interest, a suggested method should meet at least the following criteria:

- Reflect the magnitude of the power or current injections at each bus.
- Reflect the relative position of the bus in the network by considering electrical distances.
- Provide effective incentives or disincentives to the producers and consumers with respect to their relative locations and magnitudes.
- Cross subsidies must be avoided (if possible) or at least minimized.
- Be easy to understand and implement.
- Drive actors to optimization of the network.
- Be consistent with a solved power flow.

This paper presents a new power loss allocation's algorithm for deregulated electricity markets. It is based on the breakdown of the network matrix and the obtaining of the power loss at each bus. Allocation factors, which also reflect the sensitivity of the various generators in supplying demanded power, are determined in order to penalize each of the participants in the energy exchange using the network. These factors take the voltage level of each bus into account, and hence, the reactive power compensation at the level of the bus. It is therefore an incentive for consumers to produce their needed reactive energy locally.

## 2. PROPOSED METHOD

The example in figure 1, shows five independent generating and five independent distributing companies, as well as an independent system operator (ISO) who manages the transmission network. The question therefore for the ISO is how to attribute the transmission losses to the different market participants based on their actual responsibility for the origin of the losses?

Power loss allocation entails the division of the total losses within the network among the different buses,

such that:

$$P_{loss} = \sum_{k=1}^n L_k \quad (1)$$

The loss  $L_k$  in equation (1) represents the fraction of the total power losses that is allocated to bus  $k$  because of the energy exchanges between bus  $k$  and the other

buses, where  $n$  is the total number of buses in the network. This step, therefore causes a permission on for the attribution of penalties proportional to  $L_k$  to each bus at the post clearing price [4]. Additional costs, comming from the allocation procedure must be conveniently shared between producers and consumers to maintain neutrality in the finances. If both generators and loads are connected to a given bus, the allocation of transmission losses to the generating and consuming sides is done in proportion to the different figures for power flowing out of each generator and power flowing into each load.

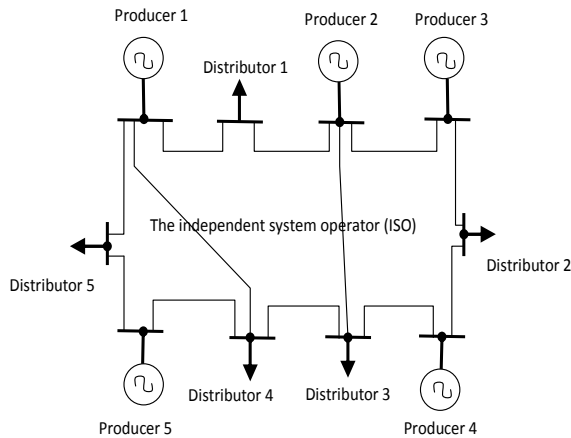

Fig. 1. Sample market structure with multiple participants

This total power loss is determined knowing consumed and supplied power as:

$$P_{loss} = \Re \left\{ \sum_{k=1}^n S_k \right\} \quad (2)$$

Let  $S_k$  be the total apparent power on bus  $k$ . This apparent power can be deducted from the power flow equations, which is written considering the network admittance matrix  $[Y] = [G] + j[B]$  as:

$$S_k = V_k I_k^* \quad (3)$$

and:

$$I_k = \sum_{j=1}^n Y_{kj} V_j \quad (4)$$

Since with this formulation, the relation between currents and power losses cannot be clearly seen, the impedance matrix  $[Z] = [Y]^{-1} = [R] + j[X]$ <sup>1</sup> is used instead. Then, the total loss given in [8] can be rewritten as:

$$P_{loss} = \Re \left\{ \sum_{k=1}^n I_k^* \left( \sum_{j=1}^n R_{kj} I_j \right) \right\} \quad (5)$$

The expression for the gross power loss at each bus becomes:

$$L_k = \Re \left\{ I_k^* \left( \sum_{j=1}^n R_{kj} I_j \right) \right\} \quad (6)$$

This expression of the power loss that's attributed to bus  $k$  in [8]. The relation can be expanded to yield the following:

$$L_k = R_{kk} I_k^2 + \sum_{\substack{j=1 \\ j \neq k}}^n R_{kj} I_j I_k \cos(\delta_j - \delta_k) \quad (7)$$

According to this relation, it is obvious that the gross power loss at bus  $k$  depends on the magnitudes and phase shifts of the different current injections at the other network nodes. It is therefore evident. These losses cannot only be attributed to the bus  $k$  in question, but should be shared to all other buses ( $j$ ) whose current injections are different from zero, and should consequently have an influence on the "produced" gross power loss at bus  $k$ .

### 3. ALLOCATION OF LOSSES TO ENERGY FLOW BETWEEN BUSES DUE TO THEIR MUTUAL INFLUENCES

Starting with equation (7) in which the gross power loss attributed to bus  $k$  is given by:

$$L_k = R_{kk} I_k^2 + R_{k1} I_1 I_k \cos(\delta_1 - \delta_k) + \dots + R_{km} I_m I_k \cos(\delta_m - \delta_k)$$

The natural grouping of the terms of this equation exposes the fraction of the gross power loss on bus  $k$  to attribute to the exchange with bus  $j$  due to their mutual effect, as:

$$L_k^j = \frac{R_{kk} I_k^2}{m} + R_{kj} I_j I_k \cos(\delta_j - \delta_k)$$

Where  $m$  is the total number of buses when the power is effectively injected or withdrawn, i.e.  $(P, Q) \neq (0, 0)$ . Transit nodes cannot have financial responsibilities.

Knowing that the crossed term of these losses and the impedance matrix are symmetrical ( $R_{kj} = R_{jk}$ ), the loss caused by bus  $j$  due to the injection of current in bus  $k$  and to their mutual effect will be gotten, as:

$$L_j^k = \frac{R_{jj} I_j^2}{m} + R_{kj} I_j I_k \cos(\delta_j - \delta_k) \quad (8)$$

So, the total loss in the network caused by the mutual effect between buses  $k$  and  $j$  will be:

$$L_{j-k} = \frac{R_{jj} I_j^2 + R_{kk} I_k^2}{m} + 2R_{kj} I_j I_k \cos(\delta_j - \delta_k) \quad (9)$$

The equation (9) shows the power loss due to the energy flow or mutual influencing between buses  $j$  and  $k$ .

<sup>1</sup> The problem of existence of the inverse of the admittance matrix  $Y$  is out of scope of this paper.

4. ALLOCATION OF TRANSMISSION LOSSES TO DIFFERENT NETWORK BUSES

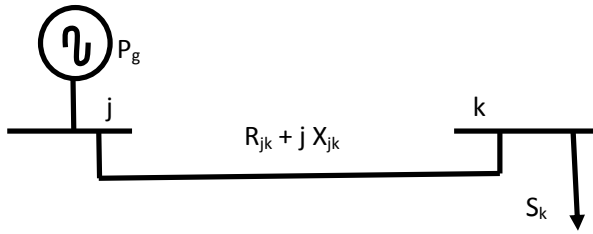

Fig.2. Energy exchange between a generator and a load

After establishing the equations 8 and 9, the next step should be used to attribute a part of the power loss to each of the buses. Considering that the loss between two buses can be seen as the power loss due to the energy exchange or mutual influence between a real or hypothetical combination of a generator and a load connected to the ends of the link ( $R_{jk} + jX_{jk}$ ) between them.

Then the active power flows from one bus to another varies with the phase difference between their voltages, while reactive power- flow varies with the potential difference between the buses.

The power flow equations with the admittance matrix  $[Y] = [G] + j[B]$  give the following relations:

$$S_j = (g - jb) \left( v_j^2 - v_j v_k \cos \delta_{jk} - j v_j v_k \sin \delta_{jk} \right)$$

$$S_k = (g - jb) \left( v_k^2 - v_j v_k \cos \delta_{jk} - j v_j v_k \sin \delta_{jk} \right)$$

And the gross power loss attributed to each bus is also:

$$L_j = g v_j^2 - g v_j v_k \cos \delta_{jk}$$

$$L_k = g v_k^2 - g v_j v_k \cos \delta_{jk}$$

So the total loss is:

$$L_{j-k} = g v_k^2 + g v_j^2 - 2g v_j v_k \cos \delta_{jk} \quad (10)$$

The objective of the allocation is to penalize the load according to its level of compensation, or power factor, while the underlying idea remains to establish the contribution of the load bus voltage on the total power loss. This can be formulated mathematically as:

$$\begin{aligned} \text{minimize } f(v_j, v_k, \cos \delta_{jk}) &= \\ &= g v_j^2 + g v_k^2 - 2g v_j v_k \cos \delta_{jk} \end{aligned} \quad (11)$$

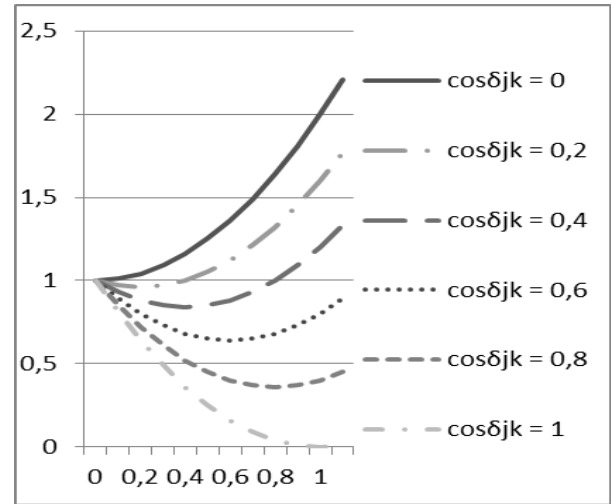

Fig. 3. Variation of power loss (Y-axis) with the bus voltage  $v_k$  (X-axis) for different values of the phase shift.  $v_j$  is here the reference voltage ( $v_j = 1$  p.u)

Bus j is considered a generator and bus k a load in the real or hypothetical exchange of energy, if  $\delta_j > \delta_k$ . If  $\cos \delta_{jk}$  is considered as a fixed voltage (it varies a little bit in networks) and  $v_j$  is taken as reference voltage (generator side), this function is minimum, when:

$$\frac{df}{dv_k} = 2g (v_k - v_j \cos \delta_{jk}) = 0 \quad (12)$$

The allocation factors for bus j and bus k can now be determined to fulfill the following conditions:

$$k_j + k_k = 1$$

If  $v_k = v_j \cos \delta_{jk}$  then  $k_j = k_k$  (13)

Besides, when the reactive power is compensated at the load bus, the effects are:

- An increase in the transmissible active power of the supply lines.
- A decrease in the cost of operation and maintenance of the alternators, because of reducing the reactive produced power.
- A decrease in the line power loss, if the compensation is well done.

Therefore, the allocation factor of a bus considered as a load must decrease when the voltage in such a bus increases, i.e. when the level of compensation increases. The allocation factors are hence the following:

$$K_k = \frac{v_j \cos \delta_{jk}}{v_k + v_j \cos \delta_{jk}}; \quad K_j = \frac{v_k}{v_k + v_j \cos \delta_{jk}} \quad (14)$$

This means, the more a “load” bus is compensated, the more its allocation factor decreases; while the reverse is true for the “generator” bus.

After establishing equation (8), the steps to follow for the allocation algorithm are:

- Determine which of the two buses, the “generator bus” and the “load bus” are depended to the sign of the phase shift of the bus voltages.
- If any one of the two buses is a transit bus (P, Q) = (0, 0), i.e. power is neither injected nor withdrawn at such a bus, then the loss is totally attributed to the other bus.
- If none is a transit bus, then the generator bus is assigned the loss given by:

$$L_{j-k}^j = K_j L_{j-k}$$

$$L_{j-k}^j = \frac{v_k}{v_k + v_j \cos \delta_{jk}} L_{j-k}$$
(15)

While the load bus k assigns the loss given by:

$$L_{j-k}^k = K_k L_{j-k}$$

$$L_{j-k}^k = \frac{v_j \cos \delta_{jk}}{v_k + v_j \cos \delta_{jk}} L_{j-k}$$
(16)

These two relations are the loss allocation of buses j and k taking mutual influence into account. So, the total power attributed to a bus j is therefore:

$$L^j = \sum_{\substack{k=1 \\ k \neq j}}^n L_{j-k}^j$$
(17)

### 5. CASE STUDY

The proposed method has been tested on the standard 14 bus-IEEE network presented in appendix, and the results compared to those of four other algorithms commonly referenced in the relevant scientific literature. This new method, unlike the other four under consideration and as exposed in table V, is consistent with the flow of reactive power within the network and gives clear incentives to invest and optimize the network. The Tables 1, 2, 3 and 4 below give the loss allocations with this new method. The data of the test network are given in the appendix.

**Table 1.** Comparison of results obtained with proposed algorithm to those of four common loss allocation methods using the basic 14 – bus network (Losses in MW)

Bus num	Active power generated	Active load demand	Voltage magnitude (p.u.)	Z-bus	Pro Rata	PS	ITL	New method
1	236.1	0.0	1.06	7.95	7.27	5.38	5.38	5.52
2	40	21.7	1.045	0.1	1.94	0.16	0.51	0.6

3	0.0	94.2	1.01	3.31	3.09	2.96	2.93	2.63
4	0.0	47.8	1.0053	2.57	1.57	3.33	3.25	1.87
5	0.0	7.6	1.0501	1.36	0.25	2.35	2.58	1.23
6	0.0	11.2	1.07	0.8	0.37	0.35	0.51	1.02
7	0.0	0.0	1.0362	0	0	0	0	0
8	0.0	0.1	1.09	-0.71	0	0	0	-0.28
9	0.0	29.5	1.02	0.51	0.97	0.66	0.56	0.94
10	0.0	9.0	1.0225	0.18	0.3	0.24	0.17	0.68
11	0.0	3.5	1.0465	0.22	0.11	0.32	0.24	0.7
12	0.0	6.1	1.0581	0.23	0.2	0.32	0.35	0.68
13	0.0	13.5	1.0468	0.05	0.44	0.06	0.26	0.51
14	0.0	14.9	1.0132	0.43	0.49	0.44	0.26	0.83
Total	276.1	259.1		17	17	17	17	17

**Table 2.** Percentage (%) of power allocated to the buses

Bus num.	Active power generated	Active load demand	Z-bus	Pro Rata	PS	ITL	New method
1	85.5	0.0	46.8	42.8	31.7	31.7	32.5
2	14.5	8.4	0.6	11.4	1.0	3	3.5
3	0.0	36.4	19.47	18.2	17.4	17.2	15.5
4	0.0	18.4	15.1	9.2	19.6	19.1	11
5	0.0	2.9	8	1.5	13.8	15.2	7.2
6	0.0	4.3	4.7	2.2	2.0	3	6.0
7	0.0	0	0	0	0	0	0
8	0.0	0.04	-4.2	0	0	0	-1.6
9	0.0	11.4	3	5.7	3.9	3.3	5.5
10	0.0	3.5	1.1	1.8	1.4	1	4
11	0.0	1.4	1.3	0.6	1.9	1.4	4.1
12	0.0	2.4	1.4	1.2	1.9	2	4
13	0.0	5.2	0.3	2.6	0.4	1.5	3
14	0.0	5.8	2.5	2.9	2.6	1.5	4.9
Total	100	100	100	100	100	100	100

**Table 3.** Comparison between the results obtained for the basic 14 – bus network using the proposed algorithm, and those obtained from four common loss allocation methods (Losses in MW)

Bus num.	Active power generated	Active load demand	Voltage mag. (p.u.)	Z-	Pro Rata	PS	ITL	New method
1	125.58	0	1.06	2.27	1.54	2.34	1.89	1.72



observed in Tables III and IV that electric distances and bus voltage levels are factors which count in the suggested method, in contrast to the case of the pro-rata and Z-bus methods. Although bus12 consumes less power than bus 5, it is bus 5 that assigns a smaller penalty. This is due to the fact that bus 5 is closer to the production centre than bus 12. In Tables I and II, bus 5 assigns a bigger penalty because of its lower voltage magnitude and its bigger deviation from the bus 12 voltage.

So, the proposed method seeks to combine several important influencing aspects to make fair loss allocations to the different market participants, without necessarily eliminating cross-subsidies. It reveals the variation of these allocations with both the power production and power consumption levels. Tables I and III clearly show this dependency. It can also be seen that as soon as a generator is added to bus 8, the change in network topology considerably modifies the production area, as well as the voltages levels due to reactive power flows. Also, it is observable that both the electric distance and the voltage level have an influence, as well as the power injected and/or power consumed. A particular load close to the generating plant can be allocated a smaller loss than one equal load further away from the generator, even if the distant load is consuming less active and reactive powers.

It is worth noting that this method may lead to negative loss allocations. This can be explained by the bus location in the network layout, and its influence on the other buses within the network. The negative value of the allocation to a bus is an indicator that the additional power-injection or withdrawal is acceptable for this bus. For example bus 8 has a good position in the network and tends to optimize the distribution of the power flows in the network. In Tables III and IV, it can be seen that as soon as a generator (100MW) is connected, the power loss decreases considerably, dropping from about 17 MW to 6.5MW (i.e. an energy gain of 38%). It is evident that this should be rewarded in the loss allocation array. The proposed algorithm shows a variation of this allocation from -1.6% to -9.88%, which exemplifies the importance of this bus and emphasizes the need to invest in it. In this new network layout (with the additional generator at bus 8), which reduces the losses in the network from 17MW to 6.5MW for active power; and from 31.2Mvar to 16.2Mvar for reactive power, previous algorithms tend on the contrary to penalize the bus in question more. Of course, this leads to wrong signals for investments aiming at optimizing the network.

## 6. CONCLUSION

This paper exposes a new power of loss allocation algorithm for the open electricity market environments. It is based on the following aspects:

- Network equations are used to obtain the overall network power loss.
- The total loss at each bus is obtained naturally by regrouping terms that are corresponded to the chosen bus.
- Expressions for the total bus loss having mixed terms are attributed to those nodes where there's the current the injection's feature.
- The overall loss is shared into account, the mutual influence of nodes and the power-flow obtained through the impedance matrix.
- Allocative factors are determined from the need to optimize losses, based on the bus voltage levels and their mutual phase shifts.

The table 5 shows a qualitative analysis of the different methods based on commonly accepted criteria.

**Table 5.** Qualitative comparison of the different methods

Criteria	Algorithms				
	Z – Bus	Pro Rata	Proportion Sharing	ITL	Proposed Algorithm
Is it quantity dependent?	Yes	Yes	Yes	Yes	Yes
Does it depend on electrical distances?	Yes	No	No	No	Yes
Is it consistent with the flow of reactive power (voltage level)?	No	No	No	No	Yes
Does it require linearity?	No	Yes	Yes	No	No
Does it produce negative losses?	Yes	No	No	Yes	Yes
Does it give clear incentives to invest and optimize the network?	No	No	No	No	Yes
Does it depend on the slack bus?	No	No	No	Yes	No

Is it easy to understand and implement?	Yes	Yes	Yes	Yes	Yes
It is consistent with a solved power flow?	Yes	Yes	Yes	Yes	Yes

From the table above, the proposed algorithm respects almost all the recommended criteria. It has numerous advantages and its own specificities. Nevertheless, it cannot lay claims to be absolute and comprehensive. Its utilization must therefore depend on the motivations of the network operator, as well as his arrangements with other market participants.

7. APPENDIX

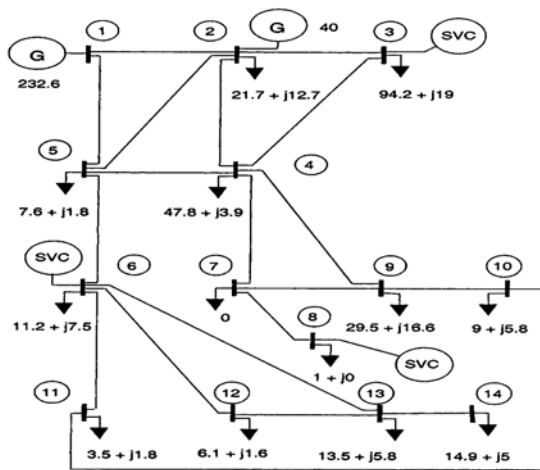

Fig. 4. One-line diagram of the 14 – bus network. Power generation and demand at every bus are given in MW

Table 6. Line Data for the 14-Bus Network used in the Case Studies

Line number	From bus	To bus	r (pu)	x (pu)	b (pu)
1	1	2	0.0194	0.0592	0.0528
2	1	5	0.054	0.223	0.0528
3	2	3	0.047	0.198	0.0438
4	2	4	0.0581	0.1763	0.0374
5	2	5	0.057	0.1739	0.034
6	3	4	0.067	0.171	0.0346
7	5	4	0.0134	0.0421	0.0128
8	4	7	0.0001	0.2091	0
9	4	9	0.0001	0.5562	0
10	5	6	0.0001	0.252	0
11	6	11	0.095	0.1989	0
12	6	12	0.1229	0.2558	0
13	6	13	0.0662	0.1303	0
14	7	8	0.0001	0.1762	0

15	7	9	0.0001	0.11	0
16	9	10	0.0318	0.0845	0
17	9	14	0.1271	0.2704	0
18	10	11	0.082	0.1921	0
19	12	13	0.2209	0.1999	0
20	13	14	0.1709	0.348	0

Figure 4 shows the one-line diagram of the 14 - bus [9] network used for the test. Table 6 shows data for different network lines. The voltage magnitude is specified in the per unit system for some buses:  $V1 = 1.06$ ,  $V2 = 1.045$ ,  $V3 = 1.01$ ,  $V6 = 1.07$  and  $V8 = 1.09$ . Base values are: 138kV and 100MVA.

REFERENCES

- [1] J. J. Gonzalez and P. Basagoiti, "Spanish power exchange market and information system. Design concepts, and operating experience," In: *Proceeding of the 1999 IEEE Power Industry Computer Applications Conference*, Santa Clara, USA, pp. 245–252, May 1999.
- [2] J. W. Bialek, S. Ziemianek, N. Abi-Samra, "Tracking-based loss allocation and economic dispatch," In: *Proceedings of the 13th Power System Computation Conference*, Trondheim, Norway, pp. 375–381, July 1999.
- [3] A. Gomez Exposito, J. M. Rimelque Santos, T. Gonzalez Garcia, E. Ruiz Velasco, "Fair Allocation of Transmission Power Losses," In *IEEE Trans. Power Syst.*, No. 15, pp. 184–188, Feb. 2000.
- [4] A. J. Conejo, J. M. Arroyo, N. Alguacil, L. Guijarro, *Transmission "Loss Allocation: A Comparison of Different Practical Algorithms,"* In: *IEEE Trans. Power Syst.*, No. 17, pp. 571–576, Aug. 2002.
- [5] J. W. Bialek, "Tracing the flow of electricity," In: *IEEE Proc. – Gener., Transm., and Distrib.*, Vol. 143, No. 4, pp. 313–320, July 1996.
- [6] D. F. Galiana, A. J. Conejo, and I. Kockar, "Incremental Transmission Loss Allocation under Pool Dispatch," In: *IEEE Trans. Power Syst.*, No. 17, pp. 26–33, Feb. 2002.
- [7] F. D. Galiana, A. J. Conejo, H. Gil, "Transmission network cost allocation based on equivalent bilateral exchanges," In: *IEEE Trans. Power Syst.*, No. 18, pp.1425–143, Nov. 2003.
- [8] A. J. Conejo, F. D. Galiana, I. Kockar, "Z-Buss loss allocation," In: *IEEE Trans. Power Syst.*, No. 16, pp. 105–110, Feb. 2001.
- [9] L. L. Ferris and A. M. Sasson, "Investigation of the load flow problem," In: *IEEE Proceedings*, No. 10, pp. 1459–1470, Oct. 1968.
- [10] J. Usaola, "A transaction-based method for allocation of transmission grid cost and losses," *Elsevier Electric Power Systems Research* 76, pp. 395–403, Sept. 2005.
- [11] C. C. Yung, T. Y. Wei, C. L. Chung, "A new method for calculating loss coefficients," *IEEE Trans. Power Syst.*, No. 9, pp. 1665–1671, Aug. 1994.
- [12] Y. Phulpin, M. Hennebel, S. Plumel, "La traçabilité de l'électricité: une méthode équitable



- pour l'allocation des coûts de transmission,”** (*The tracability of electricity: an equitable method for the allocation of the cost of transmission*) *Electrotechnique du Futur*, Grenoble: France, Jan. 2008.
- [13] N. R. Patne, K. L. Thakre, **“PSCAD/EMTDC Simulation of Power System to Study Influence of Network Parameters on Characteristic of Voltage Sag,”** *Journal of Electrical Engineering*, No. 8 , pp. 50-59, June 2008.
- [14] S. Zouzou, A. El-maouhab, A. Bensalem, **“Optimal generation dispatch of electrical energy production system,”** *Journal of Electrical Engineering*, No. 6, pp. 13-17, Dec.2006.