

Choice of Electric Engines Connection Circuits in Electric Machine Unit of Electric Power Generation Device

Andrii Hnatov¹, Shchasyana Arhun^{2*}, Oleksandr Dziubenko³, Svitlana Ponikarovska⁴

1- Vehicle Electronics Department, Kharkiv National Automobile and Highway University, Kharkiv, Ukraine.

Email: kalifus76@gmail.com

2- Vehicle Electronics Department, Kharkiv National Automobile and Highway University, Kharkiv, Ukraine.

Email: shasyana@gmail.com (Corresponding author)

3- Vehicle Electronics Department, Kharkiv National Automobile and Highway University, Kharkiv, Ukraine.

Email: dzyubenko.alan@gmail.com

4- Department of Foreign Languages, Kharkiv National Automobile and Highway University, Kharkiv, Ukraine.

Email: ponikarovska@gmail.com

Received: May 2018

Revised: July 2018

Accepted: September 2018

ABSTRACT:

The purpose of this research is to study and select the type of engine and circuits for connecting their windings in the generator operating mode of the electric machine unit for the device of converting kinetic and mechanical energy of rotation in the electric one. The design and principle of the device, which transforms the kinetic energy from pressure into an electric one, is proposed. The results of experimental studies on the determination of the most efficient type of electric engine in accordance with the value of the generated power output are presented. According to the results of the experiments, it was determined that a stepper motor DSh 200-1 is more efficient for one rotation in the forward and reverse direction with frequency $f = 1.185$ Hz. The processing of experimental research was carried out using integral methods of mathematical physics, namely the trapezoid method. Integration of the received oscillograms allowed to determine the most effective circuit of connection of stepper motor DSh-200-1 stator windings. For one rotation in the forward and reverse direction with frequency $f = 1.185$ Hz, the given circuit will provide the power of 0.164 Watt.

KEYWORDS: Electric Engines, Transformation of Electric Energy, Alternative Energy Source, Energy Saving, Electric Power Generation.

1. INTRODUCTION

Apparently the cars with internal-combustion engines harm badly the environment of the whole world, so the transition to electric vehicles is taking place in most developed countries, this kind of vehicles are more economical and more environmentally-friendly [1–5]. The issue of preservation and generation of electric energy is becoming more and more relevant all over the world. Small systems or devices which possess good “mobility” and can be easily mounted and installed in any city for alternative and decentralized power, are particularly urgent. At the same time, it means that this system (device) is capable of partial or full provision of certain consumers with electricity [6–8].

Creation and receipt of renewable energy sources that do not generate harmful emissions and do not pollute the environment is an urgent scientific and technical task [9–13]. Lately, more and more countries have declared their intentions to switch to renewable energy sources. One of the first in this issue is the

government of Scotland, which intends to completely switch to renewable energy sources starting from 2020 [14]. To implement such intentions, the whole complex of measures for development and implementation of new alternative sources of electricity are considered and applied. For this purpose the ways and methods for converting various types of energy into electric energy are used [15–18]. It is clear that such a conversion requires special technical development of devices and systems. Consequently, the development of power transformation and power generation devices is an urgent task, and its solution will not only resolve power supply issues, but will also help accelerate the transition to clean and renewable energy sources [19].

In this paper, the experimental research is carried out on the types of engines and their connection circuits in the electric motor unit of electric power generation device. Such a device has compact overall dimensions and is intended for installation in cities with a sufficient density of human flow (streets, sidewalks, public transport stops, stairs, corridors, etc.). When you

perform a step (by pressing), such a device is converting kinetic energy into electricity. The main idea of the work is to determine the most efficient engine and the circuits of connections of its stator windings in the electric machine unit of such a device. The work is based on the ways and methods of converting kinetic energy and mechanical energy of rotation into electric power, which will allow generating the necessary amount of electric energy, and will also provide the system of power supply with additional, alternative low-power sources of electric energy [20], [21].

It should be mentioned that the kinetic and potential energy are closely interrelated, and there is a constant transformation of one into the other. So, for the sake of bigger clarity and certainty, we will use the term “kinetic energy” for the integral action of kinetic and potential energy.

One of the design counterparts is the Pavegen tile developed by Lawrence Cumbell-Cook from England, which produces kinetic energy from the steps and turns it into an electric one [22]. Russian scientists Kh. Abramovich, E. Kharash and others proposed a similar solution [23]. The invention is the device, system and method for collecting energy on roads and highways using a piezoelectric generator. The drawback of the latest development is that it needs a stationary structure and requires special equipment and its installation. Inventors from the United States S. Brusaw, J. Brusaw proposed the device “Solar Road Panels”, that convert the energy of the sun into electricity, which provides the work of the panels and the newest “smart roads” [24], [25]. But their device can not convert kinetic energy from pressure into the electric one. The scientist V. Skoy invented a “Piezoelectric DC generator based on Casimir effect” [26]. The invention is classified as energy converters that operate on the basis of the use of piezoceramic materials, and can be used in any field of technology as a low-power current source. In his article [27] S. Bhatnagar considers the general possibility of obtaining electric energy by converting it from the energy of sound waves and by using piezoelectric elements. But the author considers only the fundamental possibility of such transformation and does not provide specific devices and systems that can do it. In [28], it is proposed to combine the process of converting mechanical energy into electric energy and the process of accumulation of electric energy in the form of chemical energy. The authors do not indicate the operational characteristics of their development. Publication [29] presents a method for converting an electrolytic stream into electric energy and provides a schematic implementation, but does not indicate the composition and properties of the main materials of the circuit and their performance characteristics. In paper [30], researchers justify the use of piezoelectric

converters in roads with asphalt covering in terms of efficiency and energy production. Thus, conversion of kinetic energy from pressure into electric energy is shown, but no specific technical solutions are presented for the practical use of this process. In [31] a technical review of a hybrid wind generator and photovoltaic energy converter is presented. These technical solutions are quite powerful and cumbersome. The authors of the article [32] have performed the simulation of operating characteristics of wind turbines rotated by the DC motor. In the work the circuit of simulation of a wind turbine torque is offered by control of current of a direct current motor anchor. But the article does not give the characteristics of the generated power output by the DC motor. In [33], a direct drive generator based on the principle of nonlinear switching using wave energy is investigated. Integrated with the sensorless technique, the direct-drive generator has low cost and robustness characteristics, and power generation control system is especially suitable for operation in hostile working environments, since the physical sensors are eliminated. The analysis of the efficiency of control system in power generation is presented. But researchers do not give indicators of the generated power output [32]. This does not allow to form a complex idea of the effectiveness of the electric drive in the generator operating mode. The authors of paper [34] investigate the device for converting kinetic energy from vibrations to electric energy. In this study, the prototype “Vibration Energy Harvester” was developed to evaluate its efficiency in generating electricity from the source of vibration. The main element of energy conversion is piezoelectric material. Due to the properties and technical characteristics of the piezoelectric elements, the proposed device has small gross weight. The general disadvantage of piezoelectric devices and systems is their short life, low reliability, and rather small power indices in terms of generated power output.

It seems quite promising to use stepper motors in low-power systems of power generation, which is analogous to a slab or a road surface that generates electricity [22], [35], [36] or mobile equipment like a LED torch [37]. It includes a geared step engine and an integrated electronic circuit. This source of energy is continuous, renewable and constant on condition of ongoing impact.

Works [38], [39] present the results of numerical simulation for stepper motors, but the power characteristics are not given. The urgent questions remain – how effectively the stepper motor is capable to work in the electric machine energy transformer? How much electric power and what output of it can be generated by using a stepper motor? The answers to the given questions will be sought in research of the proposed work.

The review of publications on the topic of the study shows that this topic is relevant to the wider public.

The purpose of the work is to study and select the type of engine and circuits for connecting its windings in the generator mode of the electric machine operation for the device of converting kinetic and mechanical energy of rotation in the electric energy.

2. THE DESIGN OF THE DEVICE

An electromechanical device for transformation of kinetic energy into the electric energy, in which kinetic energy from people’s steps is transformed into electric one and accumulated in capacitive storage devices - ionizers and rechargeable batteries- looks rather promising and effective. Transformation of energy occurs due to the use of an electric machine unit, in which the energy from the pressure is converted into the rotational energy of the rotor of the electric machine. Such a device can be used as an alternative and decentralized low-power source of electric energy [20], [21].

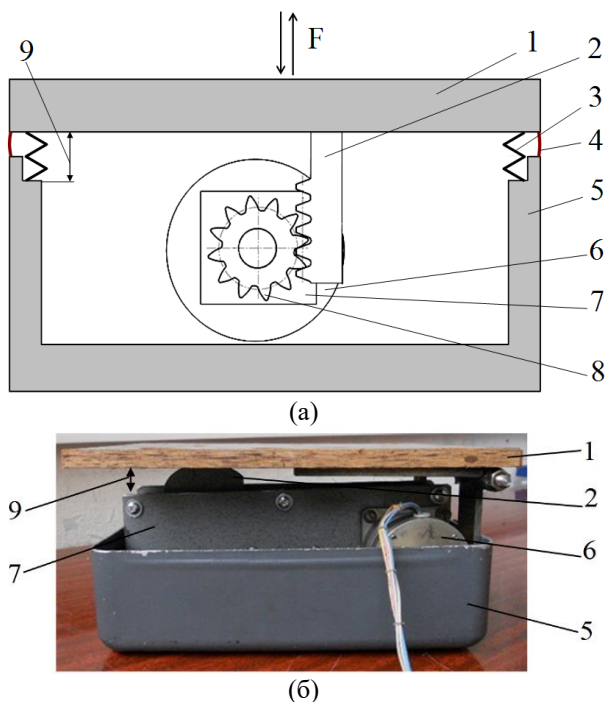

Fig. 1. (a) Scheme of the device; (b) Design of the device: (1) Push button; (2) Rail of the drive of the electric generator; (3) Spring; (4) Airtight connection of the cover with the housing; (5) Body; (6) Electric machine (electric generator); (7) Multiplier; (8) Gear drive of electric generator; (9) Working pressure of the pressure cover; (F) Pressure force.

The electromechanical device for conversion of kinetic energy into electric energy with an electric generator (reversible electric machine), which has a housing with a pressure cover, in which a rotor and a

stator are co-located, with the possibility of their movement relative to one another is offered. In this case, the same ends of the stator windings are connected to each other and go to an electric rectifier, whose output clamps are connected to a capacitive storage – ionizer. The last one, via the diode, charges the rechargeable battery, which is connected to the load via the switch (Fig. 1).

The rotor of the electric generator rotates relative to its axle under the action of the rails of the drive of the electric generator through a cylindrical multiplier, which increases the angular velocity of rotation.

The feature of the proposed device for converting kinetic energy into electric energy is that it has small dimensions and weights and can easily be installed in places with a large number of pedestrians and the great density of human flow.

3. EXPERIMENTAL STUDIES

The purpose of the experimental research is to determine the energy characteristics of various types of electric engines (reversible electric machines) and the optimal circuit for connecting their stator windings, for the best generation of electric energy with short-term mechanical influences.

In accordance with the requirements for the device of converting kinetic energy from pressure to electric energy (structural and dimensions and weights), two types of electric motors were selected: the DC motor: 45.3730 and the stepper motor, type: DS 200-1, Fig. 2.

Experimental studies consist of two parts.

1. Determination of the most efficient type of electric motor (in accordance with the value of the generated power output).
2. Determination of the most effective circuit of connection of stator windings of the electric motor.

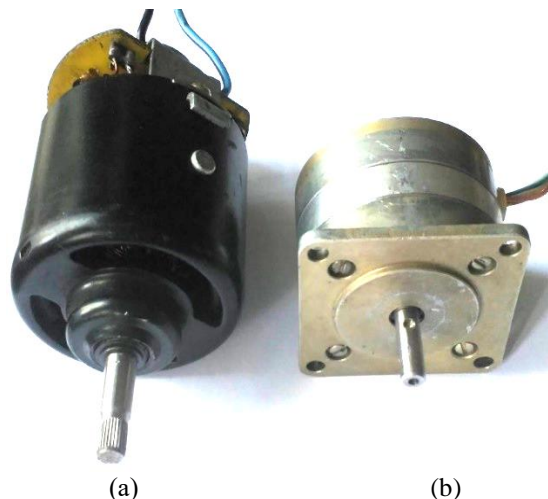

Fig. 2. Engines under Research: (a) DC motor (motor of the heater VAZ, type: 45.3730); (b) Stepper motor, type: DS 200-1.

For experimental research, a test bench (Fig. 3) was developed consisting of a block of curating (BC), a stepper motor (SM) drive, a drive stepper electric motor (DSEM) of DSh-200 type, to which the investigated electric motor (IEM) is connected in

generator mode. The voltage generated by the engine under research during rotation is fed to the rectification, filtration and load unit (RFL) and then to the measuring channel of the oscilloscope to fix the results.

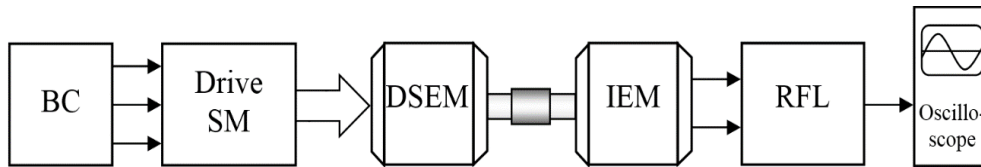

Fig. 3. The structural circuit of the test bench for the research of energy characteristics of electric motors while working as generators.

According to the principle of operation of the device for generating energy from pressure, the forced rotation of the engine is carried out when pressed via the multiplier in one direction, and when released – in the reverse, these phases are separated by a pause when transferring the weight of the human body. The whole process takes about a second, so the following time settings were selected: 300 ms per press, 100 ms pause, and 300 ms for the reverse action of the spring. The control of the drive engine is carried out in such a way that it makes one full turn in one direction, stops and makes one turn in the opposite direction, which is why the stepper motor serves as a drive motor. For all experimental studies, the rotation time of a drive electric motor is constant and steady.

In order to exclude various errors during measurements and to carry them out under the same conditions, measurements are made only on one pair of stator windings of a SM. Depending on the connection circuit of the stator windings, two circuits of the current rectification unit were used (Fig. 6).

The layout of the test bench for the research of the electrical characteristics of the electric motors as generators is shown in Fig. 4.

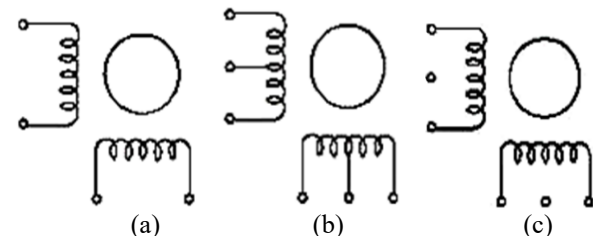

Fig. 5. Circuits of connection of DSh 200-windings 1: (a) Single-phase; (b) Unipolar; (c) bipolar.

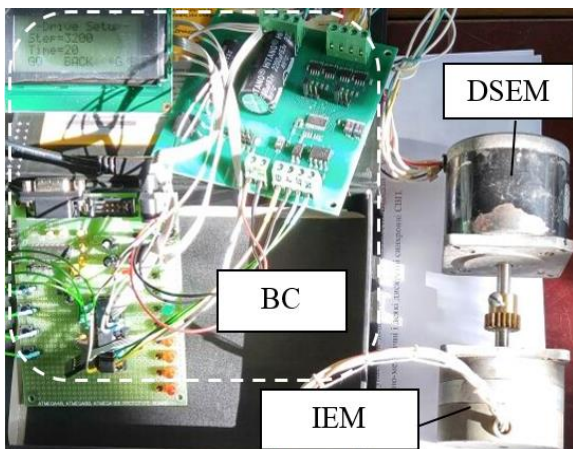

Fig. 4. The layout of the test bench.

Unlike the collector one, the stepper motor DSh 200-1 under research has two pairs of stator windings, which only allows to use one part of the winding (Fig. 5(a)), and also include them in unipolar (Fig. 5(b)) and bipolar (Fig. 5(c)) connection.

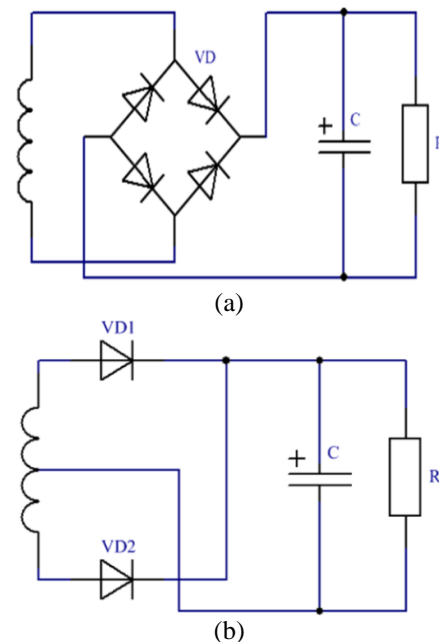

Fig. 6. Circuit of the current rectification unit: (a) Bridge circuit; (b) Midpoint circuit.

From the stator winding of the investigated electric motor, the voltage signal at the active resistance $R=18$ Ohm is measured. Thus, with load resistance (shunt) and the measured voltage dependence on time $u = f(t)$, one can calculate the dependence of the generated power output on time $p = f(t)$ in accordance with the Ohm's law [40]:

$$u(t) = R \cdot i(t) \quad (1)$$

Where, $u(t)$ is alternating voltage (V), R is active resistance of the circle (Ohm), and $i(t)$ is alternating current, A.

The instantaneous power allocated on the support is determined as follows;

$$P = ui = Ri^2 = \frac{u^2}{R} \quad (2)$$

Where, P is the instantaneous power, W; $u = u(t) = U_m \sin(\omega t + \psi_u)$; $i = i(t) = I_m \sin(\omega t + \psi_i)$. It is known that for the resistor $\psi_u = \psi_i$, then for the power p we obtain:

$$p(t) = u(t) \cdot i(t) = U_m I_m \sin^2(\omega t + \psi_u) \quad (3)$$

Where, U_m is peak value voltage (V), I_m is peak value current (A), ω is circular frequency (rad^{-1}), and ψ_u is the initial phase and voltage signal (rad).

From equation (3) we can see, that instantaneous power is always more than zero and changes in time. In these cases, the average power for period T is usually considered:

$$P = \frac{1}{T} \int_0^T p dt = \frac{U_m I_m}{T} \int_0^T \sin^2(\omega t + \psi_u) dt \quad (4)$$

After completing the integration of the obtained curves $p = f(t)$, one can determine the value of the generated power output by the stator winding of the engine under study for one turn in the forward and reverse direction.

Let's proceed to conduct experimental research on the first of these parts. The circuit of the test bench is presented in Fig. 3, the circuits of connection of stator windings of both types of engines correspond to Fig. 5(a). Initially, a research was carried out with a DC motor of type 45.3730, then with a stepper motor DSh 200-1.

The results of experimental studies for the first part are presented in Fig. 7.

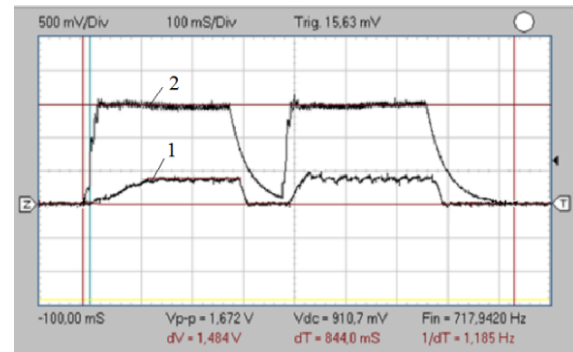

Fig. 7. Measurement of the curve of electric motor stator winding: (1) DC motor; (2) Stepper motor.

It should be noted that the measurement of the voltage curve on the DC motor was carried out without straightening the signal (without electric rectifier), while at the stepper motor, the signal was straightened by the bridge circuit. This is due to the fact that the measured amplitude values of the voltage differ by more than 3.5 times. Thus, it is obvious that the stepper motor is more efficient, so there is no need to straighten the signal from the DC motor, for further calculations. It should also be noted that the power of the signal is lost in the rectification circuit, that is, it is almost not visible (at the selected scale), which means that the apperency is lost.

In accordance with the second part of the experimental research, the definition of the most effective circuit for connecting stator windings of the stepper electric motor was carried out. Circuits of connection of stator windings of DSh 200-1 are presented in Figs. 5(b), (c). The circuit of the test bench is presented in Fig. 3. For each circuit, measurements of the generated voltage curve have been performed. The results of these studies are presented in the form of oscillograms in Fig. 8.

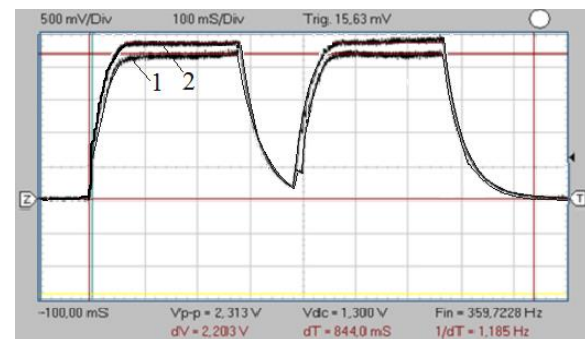

Fig. 8. Measurement of the electric motor curve DSh 200-1 stator winding: (1) Circuit of Fig. 5(b); (2) Circuit of Fig. 5(c).

4. RESULTS AND DISCUSSION

In order to obtain the diagram of generated power output in accordance with expressions (2) and (4), it is

necessary to integrate the measured oscillograms, Figs. 7, 8. Integration of oscillograms has been made according to the trapezoid method [41]

$$\int_a^b f(x)dx \approx \frac{h}{2} \cdot \left(f(x_0) + 2 \sum_{i=1}^{n-1} f(x_i) + f(x_n) \right) \quad (5)$$

Where, $[a; b]$ is segment (boundary) of integration; $h = \frac{a-b}{n}$ is step of partition, and $i = 0, 1, \dots, n$; $f(x)$ is the value of sub-integral function.

According to the conditions of the conducted experimental research expression (5), in order to determine the value of generated power output, can be written as follows:

$$P = \int_0^T p(t)dt \approx \frac{h}{2} \cdot \left(p(t_0) + 2 \sum_{i=1}^{n-1} p(t_i) + p(t_n) \right) \quad (6)$$

The results of processing of the experimental research according to expression (6) are given in the form of graphical dependence $p = f(t)$ in Fig. 9.

The values of generated power output calculated when processing experimental research by expression (5) are given in Table 1.

Table 1. Value of generated power output.

DC motor	DSh 200-1(circuits of winding connection)		
	Fig. 5(a)	Fig. 5(b)	Fig. 5(c)
0.004 W	0.069 W	0.143 W	0.164 W

The results of the calculations show that the stepper motor DSh 200-1 is more efficient for one rotation in the forward and reverse direction with frequency $f = 1.185$ Hz.

Integration of the measured oscillograms showed that the circuit diagram of the stator windings of the stepper motor, shown in Fig. 5, c is the most efficient in terms of generating power. Consequently, if the task is to get the maximum value of power generated by the electric machine unit based on the stepper motor DSh 200-1, then it is expedient to connect its stator winding according to the given circuit.

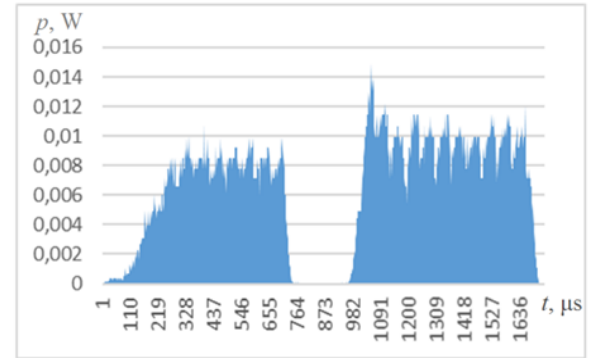

(a)

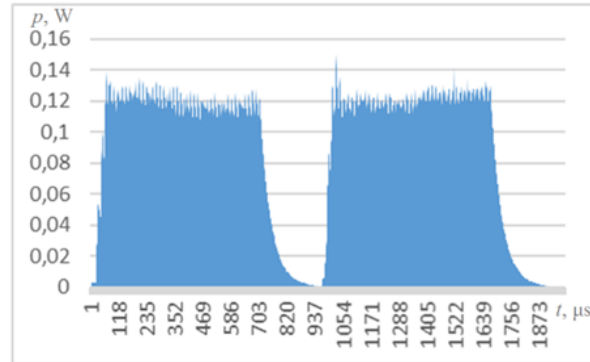

(b)

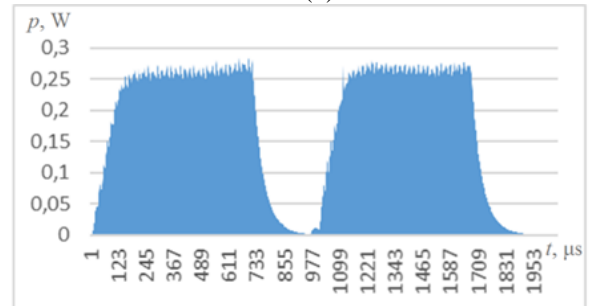

(c)

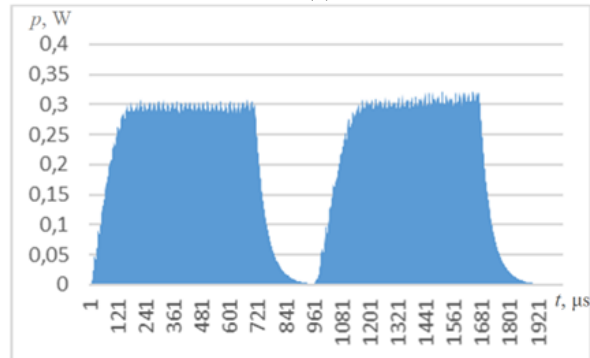

(d)

Fig. 9. Dependence of generated power output on time: (a) DC motor; (b) DSh 200-1 diagram of Fig. 5(a); (c) DSh 200-1 diagram of Fig. 5(b); (c) – DSh 200-1 diagram of Fig. 5(c).

The investigated electromechanical unit in conjunction with the speeder (multiplier), can be applied in low-power devices or systems that convert the mechanical energy of rotation into electric energy.

As it was mentioned in the introduction to the article, when the offered device is used in practice, one should take into consideration not only the kinetic energy but also the potential one. It depends on the intention and the way of using the offered device. It can be of practical use both outside (paving slabs, stairs, elements of the traffic lane, etc.) and inside the buildings. Thus, depending on the particular way of usage, the value of potential energy can sufficiently influence the share of the generated electric energy. The practical usage of Power Generation Device will be considered in detail in the future authors' works.

5. CONCLUSION

Creation and receipt of renewable sources of energy that do not generate harmful emissions and do not pollute the environment is an urgent scientific and technical task. To solve this problem, the whole complex of measures on development and implementation of new alternative sources of electricity are considered and applied. For this purpose, the methods and ways of converting various types of energy into electric energy are used.

Systems or devices possessing good "mobility" are relevant and can be easily installed and mounted in any city for alternative and decentralized power supply. This system or device is capable of partial or full provision of the designated customers with electricity.

Experimental research of the types of engines and their connection circuits in the electric machine unit of the device of generation of electric energy is presented. This device has compact dimensions and is intended for installation in cities with a sufficient density of human flow. The construction and principle of the device, which transforms the kinetic energy from pressure into electric energy, is offered.

For the experimental research, the structural circuit of the test bench was developed to determine the power characteristics of the electric motors while operating as generators. Under this circuit a stand was created for conducting experimental research.

The results of experimental studies on the determination of the most efficient type of electric motor in accordance with the value of the generated power output are presented. The results are given in the form of oscillograms of voltage on the stator winding of electric motors. According to the results of measurements, it is determined that a stepper motor DSh 200-1 is more efficient for one rotation in the forward and reverse directions with frequency $f = 1.185$ Hz.

The processing of experimental research was carried out using integral methods of mathematical physics, namely the trapezoid method. Integration of the received oscillograms allowed to determine the most effective circuit of connection of stator windings of the stepper motor DSh-200-1. It has been determined that this is exactly the connection diagram of stator windings, which is shown in Fig. 5. For one rotation in the forward and reverse direction with frequency $f = 1.185$ Hz, the given circuit will provide a power of 0.164 W.

The conducted studies are relevant and reflect a broad interest in the development of alternative low-power sources of energy, as well as energy saving and energy-efficient technologies. Implementation of the proposed solution will reduce energy supply at the expense of electricity generated by alternative sources. The device is particularly effective in places with a fair density of high human flow.

6. CONFLICT OF INTERESTS

The authors declare that there is no conflict of interests regarding the publication of this paper.

7. ACKNOWLEDGEMENTS

This work was conducted under the Scientific research "Development of the system of energy saving and electric energy generation for vehicles", 04-53-17, funded by the Ministry of Education and Science of Ukraine.

REFERENCES

- [1] A. Hnatov, S. Arhun, and S. Ponikarovska, "Energy Saving Technologies for Urban Bus Transport," *Int. J. Automot. Mech. Eng.*, Vol. 14, No. 4, pp. 4649–4664, 2017.
- [2] Research Centre for Electrical Power & Mechatronics, Indonesian Institute of Sciences Komp LIPI JICisitu 21/54D, Gd 20, Bandung 40135, Indonesia *et al.*, "A Comparison Study of Range-Extended Engines for Electric Vehicle Based on Vehicle Simulator," *J. Mech. Eng. Sci.*, Vol. 10, No. 1, pp. 1803–1816, Jun. 2016.
- [3] J. Riesz, C. Sotiriadis, D. Ambach, and S. Donovan, "Quantifying the Costs of a Rapid Transition to Electric Vehicles," *Appl. Energy*, Vol. 180, pp. 287–300, Oct. 2016.
- [4] C. Zheng, "Technical Analysis on Energy Conservation and Emission Reduction of New Energy Electric Vehicle in China," pp. 040027, 2017.
- [5] A. Hnatov, S. Arhun, O. Ulyanets, and S. Ponikarovska, "Ultracapacitors Electrobus for Urban Transport," in *2018 IEEE 38th International Conference on Electronics and Nanotechnology (ELNANO)*, Kyiv, Ukraine, pp. 539–543, 2018.
- [6] E. Ela *et al.*, "Electricity Markets and Renewables: A Survey of Potential Design

- Changes and Their Consequences,” *IEEE Power Energy Mag.*, Vol. 15, No. 6, pp. 70–82, Nov. 2017.
- [7] A. Gnatov, S. Argun, and N. Rudenko, “**Smart Road as A Complex System of Electric Power Generation**,” presented at the 2017 IEEE First Ukraine Conference on Electrical and Computer Engineering (UKRCON), pp. 457–461, 2017.
- [8] S. Nk, “**Utilization of Gravitation for Generation of Electricity as an Additional Source**,” *J. Electr. Electron. Syst.*, Vol. 5, No. 2, pp. 1–2, Mar. 2016.
- [9] S. S. Chandel, R. Shrivastva, V. Sharma, and P. Ramasamy, “**Overview of The Initiatives in Renewable Energy Sector Under the National Action Plan on Climate Change in India**,” *Renew. Sustain. Energy Rev.*, Vol. 54, pp. 866–873, Feb. 2016.
- [10] R. Corrêa da Silva, I. de Marchi Neto, and S. Silva Seifert, “**Electricity Supply Security and The Future Role of Renewable Energy Sources in Brazil**,” *Renew. Sustain. Energy Rev.*, Vol. 59, pp. 328–341, Jun. 2016.
- [11] A. Gnatov, S. Argun, and O. Ulyanets, “**Joint Innovative Double Degree Master Program ‘Energy-Saving Technologies in Transport’**,” presented at the 2017 IEEE First Ukraine Conference on Electrical and Computer Engineering (UKRCON), pp. 1203–1207, 2017.
- [12] G. A. Jones and K. J. Warner, “**The 21st Century Population-Energy-Climate Nexus**,” *Energy Policy*, Vol. 93, pp. 206–212, Jun. 2016.
- [13] M. A. Schreurs, “**The Paris Climate Agreement and the Three Largest Emitters: China, the United States, and the European Union**,” *Polit. Gov.*, Vol. 4, No. 3, pp. 219–223, Sep. 2016.
- [14] R. McGreevy, “**Scotland ‘on Target’ for 100% Renewable Energy by 2020**,” *The Irish Times*. [Online]. Available: <https://www.irishtimes.com/news/ireland/irish-news/scotland-on-target-for-100-renewable-energy-by-2020-1.3280498>. [Accessed: 03-May-2018].
- [15] B. Kroposki *et al.*, “**Achieving a 100% Renewable Grid: Operating Electric Power Systems with Extremely High Levels of Variable Renewable Energy**,” *IEEE Power Energy Mag.*, Vol. 15, No. 2, pp. 61–73, Mar. 2017.
- [16] P. Lianos, “**Review of Recent Trends in Photoelectro catalytic Conversion of Solar Energy to Electricity and Hydrogen**,” *Appl. Catal. B Environ.*, Vol. 210, pp. 235–254, Aug. 2017.
- [17] K. V. Selvan and M. S. Mohamed Ali, “**Micro-Scale Energy Harvesting Devices: Review of Methodological Performances in The Last Decade**,” *Renew. Sustain. Energy Rev.*, Vol. 54, pp. 1035–1047, Feb. 2016.
- [18] S. E. Hosseini and M. A. Wahid, “**Hydrogen Production from Renewable and Sustainable Energy Resources: Promising Green Energy Carrier for Clean Development**,” *Renew. Sustain. Energy Rev.*, Vol. 57, pp. 850–866, May 2016.
- [19] S. Banerjee, M. N. Musa, D. I. A. Jaafar, and A. Arrifin, “**Application on Solar, Wind and Hydrogen Energy - A Feasibility Review for an Optimised Hybrid Renewable Energy System**,” *J. Fundam. Renew. Energy Appl.*, Vol. 5, No. 6, pp. 1–9, Oct. 2015.
- [20] A. Patlins, A. Hnatov, N. Kunicina, S. Arhun, A. Zabasta, and L. Ribickis, “**Sustainable Pavement Enable to Produce Electricity for Road Lighting Using Green Energy**,” in *2018 IEEE International Conference on Energy and Sustainability in Small Developing Economies*, pp. (submitted), 2018.
- [21] A. В. Гнатов, Ш. В. Аргун, and Г. А. Гнатова, “**Пристрій генерування електричної енергії**,” 106587, 25-Apr-2016.
- [22] “**Pavegen founder Laurence Kemball-Cook**,” *The Engineer*, 14-Nov-2011. .
- [23] X. Абрамович, Е. Хараш, Ч. Милгром, У. Амит, and Л. Эдери Азулай, “**Сбор энергии с дорог и взлетно-посадочных полос**,” 2482568, 2013.
- [24] S. Brusaw and J. Brusaw, “**Solar Roadway Panel. US Patent**,” US D712,822 S, 2014.
- [25] “**Welcome to Solar Roadways**,” *Solar Roadways*. [Online]. Available: <http://www.solarroadways.com/>. [Accessed: 01-Apr-2018].
- [26] В. Р. Ской, “**Пьезоэлектрический генератор постоянного тока на основе эффекта казимира**,” RU Patent 2499350, 2499350, 2013.
- [27] S. R. Bhatnagar, “**Converting Sound Energy to Electric Energy**,” *Int. J. Emerg. Technol. Adv. Eng.*, Vol. 2, No. 10, pp. 267–270, 2012.
- [28] X. Xue, S. Wang, W. Guo, Y. Zhang, and Z. L. Wang, “**Hybridizing Energy Conversion and Storage in a Mechanical-to-Electrochemical Process for Self-Charging Power Cell**,” *Nano Lett.*, Vol. 12, No. 9, pp. 5048–5054, Sep. 2012.
- [29] L. Liu, H. Lim, W. Lu, Y. Qiao, and X. Chen, “**Mechanical-to-Electric Energy Conversion by Mechanically Driven Flow of Electrolytes Confined in Nanochannels**,” *Appl. Phys. Express*, Vol. 6, No. 1, p. 015202, Jan. 2013.
- [30] S. Cafiso, M. Cuomo, A. Di Graziano, and C. Vecchio, “**Experimental Analysis for Piezoelectric Transducers Applications into Roads Pavements**,” *Adv. Mater. Res.*, Vol. 684, pp. 253–257, 2013.
- [31] “**Decentralized Autonomous Hybrid Renewable Power Generation**.” [Online]. Available: <https://www.hindawi.com/journals/jre/2015/856075/>. [Accessed: 03-May-2018].
- [32] L. Gao and Y. Luo, “**Simulation of Imitation of the Characteristics of Wind Turbine Based On Dc Motor with MATLAB**,” in *2009 International Conference on Sustainable Power Generation and Supply*, 2009, pp. 1–5.
- [33] J. F. Pan, Y. Zou, N. Cheung, and G. Cao, “**The Direct-Drive Sensorless Generation System for Wave Energy Utilization**,” *Int. J. Electr. Power Energy Syst.*, Vol. 62, pp. 29–37, Nov. 2014.
- [34] “**Scavenging Energy from Human Activities Using Piezoelectric Material - ScienceDirect**.” [Online]. Available:

- <https://www.sciencedirect.com/science/article/pii/S212017314001716>. [Accessed: 03-May-2018].
- [35] A. T. Papagiannakis, S. Dessouky, A. Montoya, and H. Roshani, “**Energy Harvesting from Roadways**,” *Procedia Comput. Sci.*, Vol. 83, pp. 758–765, Jan. 2016.
- [36] “Power Generating Slabs: Lost energy conversion of human locomotive force into electrical energy - IEEE Conference Publication.” [Online]. Available: <https://ieeexplore.ieee.org/document/7026831/>. [Accessed: 03-May-2018].
- [37] Swagatam, “Build a Simple Hand Crank Flashlight,” *Brighthub Engineering*, 18-Oct-2013. [Online]. Available: <https://www.brighthubengineering.com/diy-electronics-devices/109647-how-to-build-a-magneto-crank-flashlight/>. [Accessed: 19-Jun-2018].
- [38] I. Ionică, M. Modreanu, A. Morega, and C. Boboc, “**Design and Modeling of a Hybrid Stepper Motor**,” in *2017 10th International Symposium on Advanced Topics in Electrical Engineering (ATEE)*, pp. 192–195, 2017.
- [39] “Numerical modelling of the rotor movement in a permanent-magnet stepper motor - IET Journals & Magazine.” [Online]. Available: <https://ieeexplore.ieee.org/abstract/document/6786889/>. [Accessed: 03-May-2018].
- [40] J. Bird, “Electrical Circuit Theory and Technology: Amazon.co.uk: John Bird: 9781856177702: Books,” 2010. [Online]. Available: <https://www.amazon.co.uk/Electrical-Circuit-Theory-Technology-John/dp/185617770X>. [Accessed: 03-May-2018].
- [41] L. D. English and D. Kirshner, Eds., *Handbook of International Research in Mathematics Education*, 2 edition. New York: Routledge, 2008.