

Design and Fabrication of Ultra Wide-Band Bandpass Filters with Notched-Band using a Rectangular Ring Resonator

Babak Zamanpoor¹, Ahmad Reza Eskandari^{2*}

1- Department of Electrical Engineering, East Tehran Branch, Islamic Azad University, Tehran, Iran.

Email: babakzamanpoor@gmail.com

2- Department of Electrical Engineering, East Tehran Branch, Islamic Azad University, Tehran, Iran.

Email: ar_eskandary@yahoo.com (Corresponding author)

Received: April 2019

Revised: August 2019

Accepted: September 2019

ABSTRACT

In this work, Ultra Wide-Band (UWB) microwave filters are designed and fabricated using a rectangular ring resonator. The UWB microwave filters work in the 3.1GHz to 10.6GHz frequency band, which is designed to coverage the FCC frequency spectrum for UWB systems. These filters, in addition to being ultra-wideband, are designed to prevent interference in some frequency bands, such as WiMAX band (3.5GHz), WLAN band (5.2-5.8GHz) and satellite communication systems (8GHz) band. For this reason, in designing these filters intelligently, it is necessary to take precautions to ensure producing narrow and precise notches in the frequency response to prevent interference. This broad bandwidth and narrow notches with adjusted even or odd mode resonator frequencies, can be controlled by varying the characteristic impedance of the rectangular ring resonator. The proposed structures are simulated and optimized using HFSS software, so that the results of fabrication and measurement of these filters have an excellent agreement with the simulation results.

KEYWORDS: Bandpass Filter, Ultra Wide-Band (UWB), Rectangular Ring Resonator, Notched-Band.

1. INTRODUCTION

According to the decision of the FCC in 2002, a bandwidth of 3.1-10.6GHz was dedicated to UWB. UWB filters with high efficiency and low-cost are fundamental elements of UWB communication technology. It is very important in filter design for UWB that these filters do not interfere with substantial frequency bands such as 3.5 GHz for Wi-Fi band, 5.2-5.8 GHz for WLAN band and 8 GHz for satellite communication technology band [1]. For this reason, in designing these filters intelligently, it is necessary to take precautions to ensure producing narrow and precise notches in the frequency response to prevent interference.

Recently, the wideband band-pass filter considering the signal interference based on ring resonator has been proposed and introduced. The wide pass-band and narrow notched-band with adjusted odd or even mode resonator frequencies can be available easily by varying the characteristic impedance of the resonator [2-4]. Transmission zeros are created to amend selectivity and harmonic cancellation of the proposed UWB band-pass filters with notched-bands. To inquire the accuracy of this method, three of these filters are designed and simulated with a bandwidth of around 110% [5], [6].

The UWB filter proposed in this paper, has a good in

band and out of band performances and simple structure can be reached. This paper discusses the design of an UWB filter using a rectangular ring resonator that uses short circuit stub in one of its. Simulations run with HFSS software, and finally samples are fabricated and their parameters are measured.

2. UWB BAND-PASS FILTER BY USING RECTANGULAR RING WITH A SHORT CIRCUIT STUB

Fig.1 shows a rectangular ring resonator loaded a short circuit stub on one side of it. If the odd or even mode signal are excited, an actual short or open appears along the center of ring and therefore, the circuit model for these states is equivalent to Fig.1. The even and odd mode input admittances are given in equations (1), (2) [7-9]:

$$Y_{ine} = j \frac{\tan \theta_{1/2}}{Z_1} + j \frac{\tan \theta_1 - \frac{(Z_1 \cot \theta^2)}{2Z_2}}{Z_1 + (Z_1^2 \tan \theta_1 \cot \theta_2) / 2Z_2} \quad (1)$$

$$Y_{ino} = -j \frac{\cot \theta_1}{Z_1} - j \frac{\cot \theta_{1/2}}{Z_1} \quad (2)$$

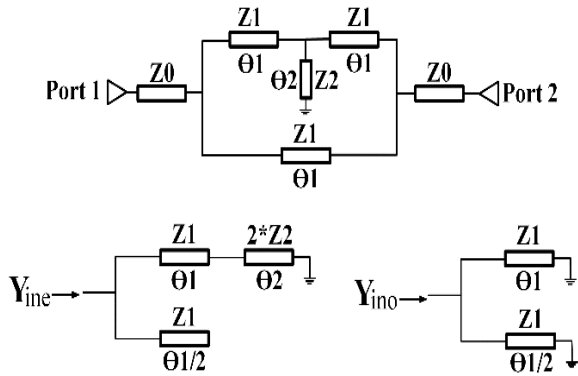

Fig. 1. Equivalent circuit for even-mode and odd-mode.

The resonant frequencies for the odd or even mode can be obtained when $Z_{ine}/Z_{ino} = 0$ or ∞ . The bandwidth for the rectangular ring is directly calculated by the odd or even mode resonator frequencies. The sufficient bandwidth (UWB) is provided by correct selection of transmission lines, electrical length and characteristic impedance values. For this purpose, the appropriate values are selected for the parameters of Fig. 2 and the simulations are done by the HFSS software. The values of these parameters are given in Table 1. The results of the frequency response curves of the scattering parameters related to the simulated filter are shown in Fig. 3. These parameters are calculated and optimized based on the change of one parameter and the keep fixed of the remaining parameters. This structure is designed on a dielectric substrate with: $h=0.8$ mm, $\epsilon_r=3.55$, and $\tan \delta = 0.002$.

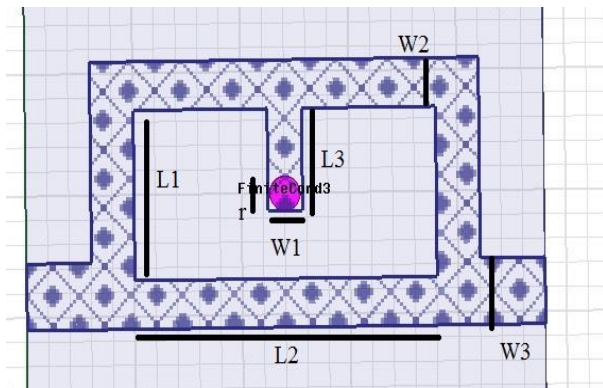

Fig. 2. Simulated structure with HFSS software.

Table 1. The values of the parameters for the filter structure of Fig. 2 (Unit: mm).

Parameter	L1	L2	L3	W1	W2	W3	r
Value	3.5	6.11	2.1	0.8	0.8	1.37	0.35

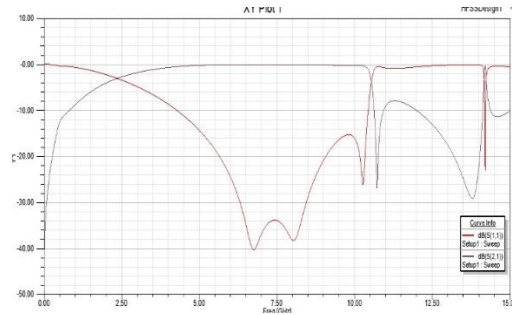

Fig. 3. Scattering parameters of the filter in Fig. 2.

3. DESIGN OF UWB BPF WITH SINGLE NOTCHED-BAND IN 5.6 GHZ

To omit the interference from WLAN signals (5.3-5.7 GHz), a UWB BPF with a notched-band is presented, to prevent the interference by using the weakness created by this notched. For this purpose, a shunt open stub with characteristic impedance Z_3 and electrical length Θ_3 is connected in the center of above path and on the short circuit of the rectangular ring resonator (Fig.4). In this case, the odd mode input admittance is the same as equation (3), but the even mode input admittance can be calculated as [10-15]:

$$Y_{ine} = j \frac{\tan \theta_{1/2}}{Z_1} + j \frac{\tan \theta_1 - \frac{(Z_1 \cot \theta_2)}{2Z_2} + (Z_1 \tan \theta_3)/2Z_3}{Z_1 + \frac{(Z_1^2 \tan \theta_1 \cot \theta_2)}{2Z_2} - \frac{(Z_1^2 \tan \theta_1 \tan \theta_3)}{2Z_3}} \quad (3)$$

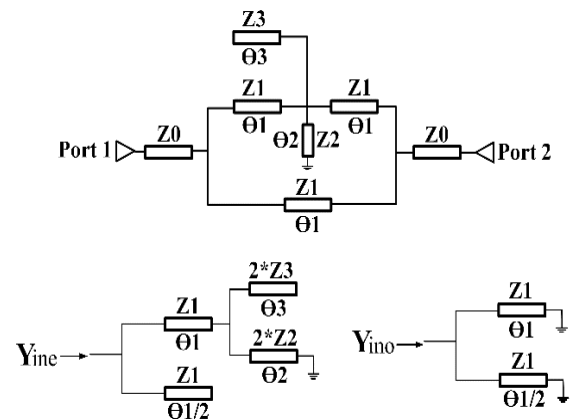

Fig. 4. Equivalent circuit for the second proposed filter.

To illustrate the behavior of this filter, the layout of Fig.5 is simulated using HFSS software, and the values of its parameters are given in Table 2. The changes and optimization of the parameters are used to adjust the center frequency of the notched-band at the 5.6GHz. In Fig.6, the simulation results are considered.

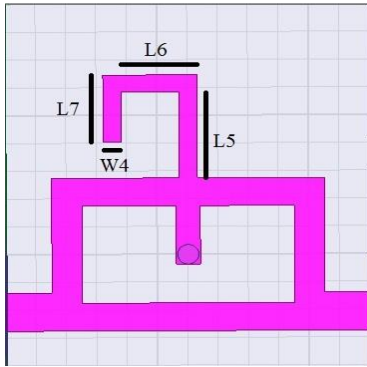

Fig. 5. Simulated structure of the second proposed filter with HFSS software.

Table 2. The values of the parameters for the filter structure of Fig. 5 (Unit: mm).

Parameter	L5	L6	L7	W4
Value	3.11	2.8	2.4	0.6

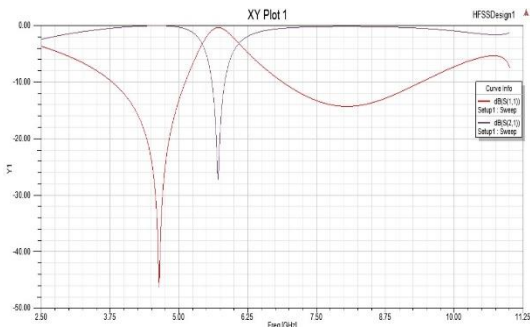

Fig. 6. Scattering parameters of the filter in Fig. 5.

4. UWB BPF WITH TWO NOTCHED BANDS IN 3.5 GHz AND 8 GHz

To omit the interference effect in 3.5 GHz band WiMax and 8 GHz band satellite communication technology, a UWB filter with two notched bands is proposed. To achieve this purpose, as shown in Fig.7, two transmission lines are used with characteristics impedances Z_3 and Z_4 , and electrical lengths θ_3 and θ_4 , is connected in the center of above ring. Moreover, the even or odd mode equivalent circuits for the rectangular ring with the open or shorted circuit stubs are presented in Fig.7. In this case, the input impedance for the odd-modes is according to the first filter, and the input impedance for the even-modes changes as illustrated in the following equation [7]:

$$\begin{aligned}
 Y_{ine} &= j \frac{\tan \theta_{1/2}}{Z_1} + j \frac{\tan \theta_1 - \frac{(Z_1 \cot \theta_2)}{2Z_2}}{Z_1 + \frac{(Z_1^2 \tan \theta_1 \cot \theta_2)}{2Z_2}} \\
 &+ \frac{(Z_1 Z_3 \tan \theta_4 + Z_1 Z_4 \tan \theta_3) / (2Z_3 Z_4 + 2Z_3^2 \tan \theta_3 \tan \theta_4)}{- (Z_1^2 Z_3 \tan \theta_4 + Z_1^2 Z_4 \tan \theta_3) / (2Z_3 Z_4 + 2Z_3^2 \tan \theta_3 \tan \theta_4)} \quad (4)
 \end{aligned}$$

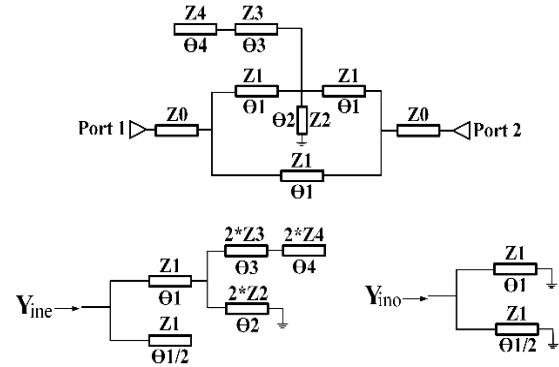

Fig. 7. Equivalent circuit for the third proposed filter.

When Z_0 , Z_1 , Z_2 , θ_1 and θ_2 are fixed, the input admittance of circuit is the following as equation (5). When Y_{SIR} goes to ∞ , we will have: $Z_4/Z_3 = \tan \theta_3 \tan \theta_4$; In this case, two different notches are produced. To see the two notched bands center frequencies placed at 3.5GHz and 8GHz, Z_3 should be less than Z_4 . In this case, the center frequency of the first notched band can be regarded as the main resonance frequency; also the center frequency of the second notched band can be less than three times the first one [7].

$$Y_{SIR} = jY_3 \frac{Z_3 \tan \theta_4 + Z_4 \tan \theta_3}{Z_4 - Z_3 \tan \theta_3 \tan \theta_4} \quad (5)$$

Finally, simulation of this filter is presented in Fig.8. To improve the results, the dimensions of the filter is optimized using the electromagnetics simulator. The optimized values of the parameters are presented in Table 3, and the results of the simulation are presented in Fig.9.

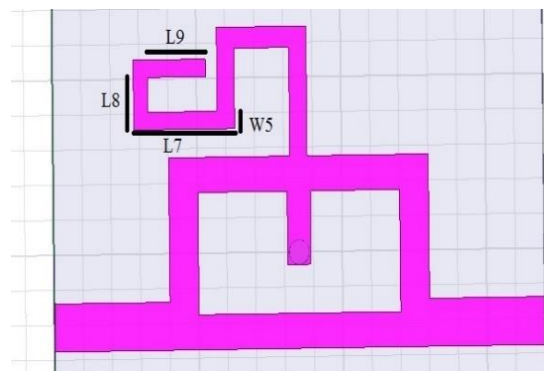

Fig. 8. Simulated structure of the third proposed filter with HFSS software.

Table 3. The values of the parameters for the filter structure of Fig.8 (Unit: mm).

Parameter	L7	L8	L9	W5
Value	3.9	1.5	2.5	0.5

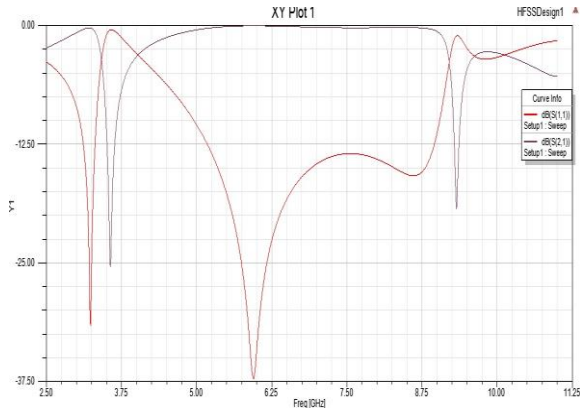
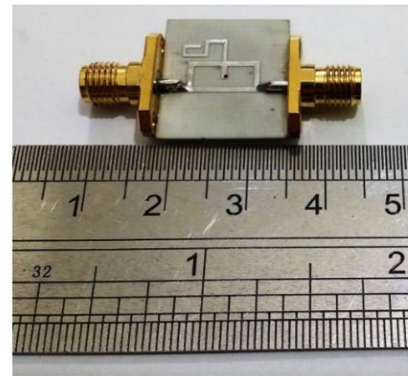

Fig. 9. Scattering parameters of the filter in Fig. 8.



(c)

Fig. 10. Photographs of the fabricated filters.

5. MEASURED AND FABRICATED RESULTS

The finalized simulated filters are fabricated on Rogers 4003 substrate with dielectric constant of 3.65 and thickness of 0.5mm. The dimensions of each of the filters are 17*16 mm². The fabricated filters are shown in Fig.10: UWB filter without notched band in Fig.10 (a), UWB filter with single-notched band (5.6GHz) in Fig.10 (b), and UWB filter with double-notched band (3.5GHz and 8GHz) in Fig.10 (c), are seen. The scattering parameters of these UWB filters, are measured by Network Analyzer in Iran Telecommunication Research Center (ITRC), and are shown in Fig. 11.

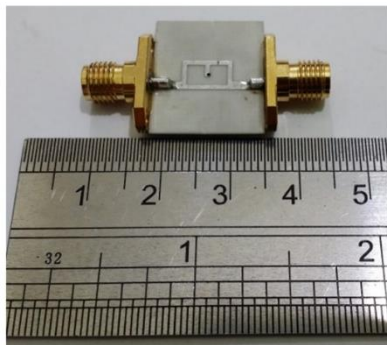

(a)

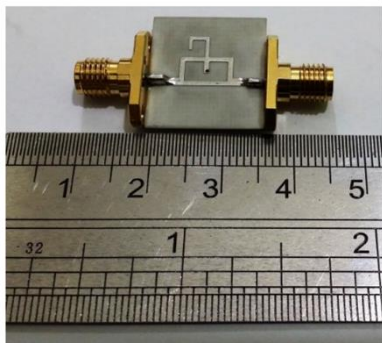

(b)

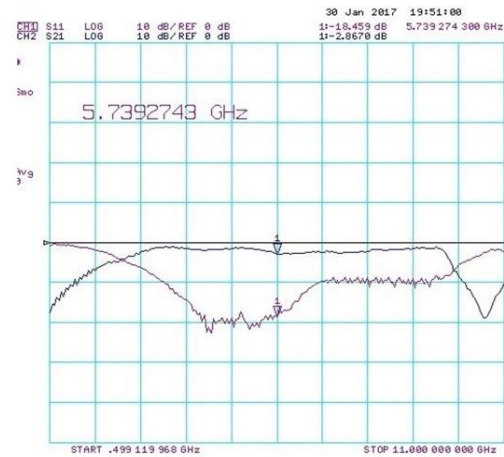

(a)

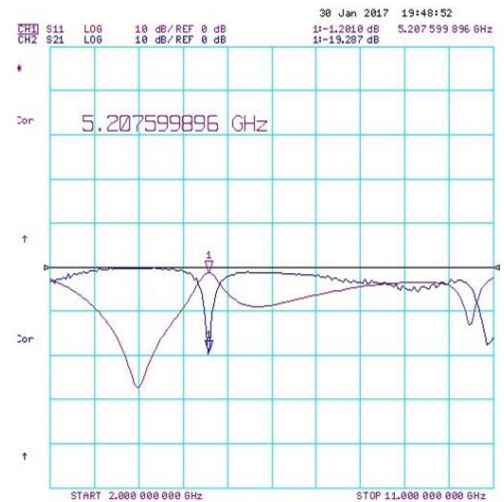

(b)

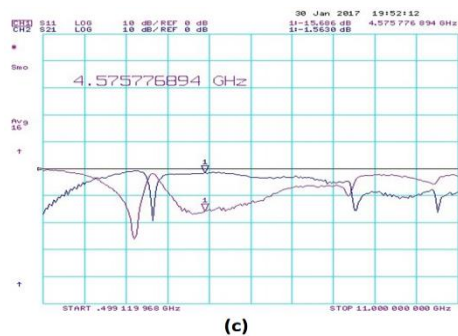

Fig. 11. Measured results of the scattering parameters for the fabricated filters.

6. CONCLUSION

The purpose of this paper is to design and fabricate UWB filters in the frequency range of 3.1~10.6 GHz, in order to prevent interference in some frequency bands, such as WLAN band, WiMAX band, and satellite communication technology band. Research on selected structures has proved that the filters designed based on one or more analytical equations are far simpler than filters that have an innovative structure. In this paper, three samples of these types of filters are simulated and fabricated: UWB filter without notched, UWB filter with single notched-band and UWB filter with two notched-band; so that good agreements between results of simulation and measurement of these filters are observed.

REFERENCES

- [1] M. Abbosh, "Design Method for Ultra-Wideband Bandpass Filter With Wide Stopband Using Parallel-Coupled Microstrip Lines," *IEEE Transactions on Microwave Theory and Techniques (MTT)*, Vol. 60, No. 1, pp. 31-38, 2012.
- [2] D. D. Wentzloff, F. S. Lee, D. C. Daly, M. Bhardwaj, P. P. Mercier, and A. P. Chandrakasan, "Energy Efficient Pulsed-UWB CMOS Circuits and Systems", *IEEE International Conference on UWB, Singapore*, Sep. 2007.
- [3] C.L. Hsu, F.C. Hsu, and J.T. Kuo, "Microstrip Bandpass Filters for Ultra Wide Band (UWB) Wireless Communication", *Microwave Symposium Digest, 2005 IEEE MTT-S International*, Jun. 2005.
- [4] A.K. Keskin, H.P. Partal, "An UWB High-Q Bandpass Filter with Wide Rejection Band using Defected Ground Structures", *IEEE International*

- Conference on Ultra-Wideband Syracuse*, Sep. 2012.
- [5] D.K. Chang, *Field Wave Electro Magnetis*, Second Edition, Addison Wesley 1981.
- [6] O. Mousavi, A.R. Eskandari, M.M.R. Kashani, M.A. Shameli, "Compact UWB Bandpass Filter with Two Notched Bands Using SISLR and DMS Structure", *Progress In Electromagnetics Research*, Vol. 80, pp. 193-201, 2019.
- [7] W. Feng, W. Che, and Q. Xue. "Compact Ultra-wideband Bandpass Filters with Narrow Notched Bands based on a Ring Resonator", *IET Microwaves, Antennas & Propagation*, Vol. 7, No. 12, pp. 961-969, 2013.
- [8] M. J. Gao, L.S. Wu, and J.F. Mao, "Compact Notched Ultra-Wideband Bandpass Filter with Improved Out-of-band Performance using Quasi Electromagnetic Bandgap Structure", *PIER*, Vol. 125, pp. 137-150, 2012.
- [9] L. T. Tang, D. B. Lin, C. M. Li, and M. Y. Chiu, "Ultra-Wideband Bandpass Filter Using Hybrid Microstrip-Defected-Ground Structure", *Microwave and Optical Technology Letters (MOP)*, Vol. 50, No. 12, pp. 3085-3089. 2008.
- [10] D. Donnell, M. S. W. Chen, S. B. T. Wang, R. W. Brodersen, "An Integrated, Low Power, Ultra-Wideband Transceiver Architecture for Low Rate, Indoor Wireless Systems", *IEEE CAS Workshop on Wireless Communications and Networking*, USA, September, 2002.
- [11] J.S. Hong, M.J. Lancaster, *Microstrip Filters for RF/Microwave Applications*, John Wiley & Sons, 2001.
- [12] G. L. Matthaei, "Design of Parallel-coupled Resonator Filters", *IEEE Microwave Magazine*, Vol. 8, Issue 5, 2007.
- [13] Y. Liu, J.C. Liu, and J.C. Xu. "Compact tri-notched ultra Wide Band Bandpass Filter Design using CSRR, DGS, and FMRR Configurations", *International Journal of RF and Microwave Computer-Aided Engineering*, Vol. 24, No. 5, pp. 571-579, 2014.
- [14] Y. Peng, and F. Xu. "Coplanar-Waveguide Ultra-Wideband Bandpass Filter Based on Interdigital Structure", *First International Conference on Information Science and Electronic Technology*, Atlantis Press, 2015.
- [15] X. H. Wang, H. Zhang, and B. Z. Wang. "A Novel Ultra-wideband Differential Filter based on Microstrip Line Structures", *IEEE Microwave and Wireless Components Letters*, Vol. 23, No. 3, pp. 128-130, 2013.