

Optimization of FACTS Devices to Reduce Losses in Transmission Networks Using HSA

Nasim Khosouie^{a,*}

^a Department of Electrical and Computer Engineering, Yasuj University, Yasuj, Iran

Received 02 October 2023; Revised 21 November 2023; Accepted 22 November 2023

Abstract

Given the high costs of investment for transmission network development and the key role of transmission networks in restructured space, using FACTS devices is crucial. In this paper, optimal Placement of FACTS in transmission networks is investigated. In the proposed method, the objective function is defined for loss reduction. Average models available in references are used for modelling FACTS devices. Multi-objective harmony search algorithm is used for problem solving. This algorithm has good speed in convergence of non-linear problems. In numerical studies section, the problem is solved in two different scenarios with presence of different types of FACTS devices. Results of numerical studies indicate that FACTS devices can have considerable impact on loss reduction.

Keywords: Harmony search (HS) algorithm; FACTS devices; loss reduction; optimal placement, capability

1. Introduction

Transmission networks in power systems have always been a determining factor. Due to the fact that the construction of transmission lines is done at a relatively significant cost, so it is very important to make the most of the installed lines. In many countries, including Iran, the capacity of installed transmission lines is sometimes up to several times the capacity of power plants. There are various reasons for this, including the limitation of power transmission over long distances. Transmission lines, especially if constructed over long distances, face transmission capacity limitations and voltage drops. To solve this problem, networks with different voltage levels are designed and it is often tried to build transmission lines as short as possible. But in the end, another solution is to use fax machines in transmission networks. These devices have different effects on the performance of transmission networks, the most important of which is to improve the voltage of the network and provide the reactive power required by the network. FACTS devices are regarded as the key equipment in transmission networks. Locating and determining parameters of FACTS devices has been always considered by the researchers in this field. In (Irshad et al., 2022), generally focus on locating and parameters of utilization of OUPFC.

The main purpose of equipment installation in the network includes two parts of network loss reduction and fuel cost reduction of generators. In (Lashkar Ara et al., 2011), investigates locating problem for a STATCOM in a network. In this paper an index known as Fast Voltage Stability Index (FVSI) is introduced and used for determining critical lines. The problem of adding FACTS devices in a sample network considering network security

is examined in (Shintemirov et al., 2010). In this paper OUPFC has been used. Objective function in this paper is defined for reduction of loss and generator fuel cost in the network. In (Avinash et al., 2015), studies problem of locating and determining parameters of a TCSC in a sample network. Current paper aims at reducing network loss and genetic algorithm with DE algorithm combination is used for problem solving. The stated mathematical relations are similar to the previous papers to large extent. The problem approach is not dynamic in this paper. Since the installation location is an integer variable, thus the problem is of MINLP type. Results of numerical studies on a sample network indicate that combined use of two optimization algorithm can give good results in this relation. In (Javadian et al., 2022), has similar approach to this paper. With the difference that use of FACTS devices in (Sharma et al., 2005), is raised in general, and regulatory parameters are not discussed. The algorithm used in (Jordehi et al., 2011), is also DE. In (Kavitha et al., 2016), discusses on parallel FACTS devices in the network. In this paper an optimization problem is defined by which the parallel FACTS devices extend in the network. Objective function contains two parts of network voltage improvement and capacity reduction of FACTS devices. In (Kowsalaya et al., 2008), SVC and STATCOM equipment are used in the network. Considering characteristics of these equipment in series and parallel branches, their combined usage provides good results. The relations used in description of FACTS devices in papers (Arabkhaburi et al., 2006), are similar. Locating and determining capacity of FACTS devices in a transmission network are studied in (Ghamgeen et al., 2012). The main purpose in this paper is releasing network line capacity. Equipment used in this paper includes SSSC

* Corresponding author Email address N.khosouie@yu.ac.ir

and STATCOM. Since SSSC is a controllable capacitor which is installed as series in the network, and STATCOM has parallel branch, it can be stated that series and parallel equipment are simultaneously used. The main purpose in this paper is releasing network line capacity. Thus an index known as density index is defined for network lines which finally density of network lines can be reduced by minimizing it. Parallel FACTS devices are used in (phadke et al., 2012). There are different approaches in these papers in problem solving, but objective functions of both papers are defined for network loss reduction. In (Baghaee et al., 2008), specifically focuses on STATCOM. Different models of STATCOM are studied in (Kiani et al., 2023). In this paper, the main purpose is providing an accurate and near to real-world model for STATCOM, using of which proper understanding of this device can be achieved. In this paper it is stated that the introduced model is appropriate for voltage stability and angle in network studies. In (Ildarabadi et al., 2017), the authors attempt to determine the best location and capacity for a UPFC using a multi-purpose optimization problem. Objective function in this paper is defined similar to Reference (Malakar et al., 2010), in line with network loss reduction. Both papers have used genetic algorithm for their problem solving. The difference in papers (Gaur et al., 2018), is in the used devices. UPFC is also used in the network in (Bindeshwar et al., 2010). Addition of FACTS devices to network is investigated in papers (Rahimzadeh et al., 2011). These papers similar to many other reviewed ones added FACTS devices aiming at network loss reduction. The difference in these papers is the way of consideration of network constraints.

2. Definition of Problem

Main purpose of this problem is optimal Placement FACTS devices in network. To this end, three types of FACTS devices were used: Static Synchronous Series Compensator (SSSC), Static Synchronous Compensator (STATCOM), Unified Power Flow Controller (UPFC) computational methods.

2.1. Problem of Optimization

Each optimization problem consists of the following different parts: Problem variables, The Objective Function, Problem Limitations

2.1.1. Variables of Problems

The main purpose of this paper is to solve the problem of optimal location and determine the parameters of FACTS devices in the network. The main variable of the problem includes the place of installation and adjustment of the parameters of these devices. The following equation shows the problem variables (Rahmani et al., 2023).

$$X = \begin{bmatrix} Location \\ parameters \end{bmatrix} X = \begin{bmatrix} Bus_{upfc} \\ Bus_{sssc} \\ Bus_{statcom} \end{bmatrix} \quad (1)$$

As can be seen, the problem variables consist of two general parts. The first part includes the installation location of FACTS devices and the second part includes the adjustment parameters of these devices.

2.1.2. Objective Function

The objective function is defined in the following sections: Increase Total Transmission Capacity: Total transmission capacity includes the amount of network capacity for power exchange. In this paper, a repetitive load flow method has been used to calculate this value. Reduce Transmission Network Losses: transmission network losses are caused by current passing through lines. In fact, as electricity flows through transmission lines, these lines heat up and practically lose some of their energy. Transmission network losses depend on the type of transmission lines, the cross section of the lines, the amount of current passing through the lines and some environmental parameters. In this paper, the effect of environmental conditions such as temperature on the rate of losses is ignored. The following equation is used to calculate network losses (Esmaili et al., 2023).

$$F_2 = \sum_{l=1}^{NL} P_l = \sum_{i=1}^n \sum_{j=1}^n |V_i| |V_j| |Y_{ij}| \cos(\theta_{ij} + \delta_j - \delta_i) \quad (2)$$

Where,

Y_{ij} : Network admittance in term of p.u.

θ : Network admittance angle in terms of radian

δ : Network voltage angle in terms of radian

It can be seen that the coefficient of importance is used in this part. These coefficients can control the objective function of the problem. If we want to pursue a part of the objective function with more importance, we use significance coefficients. Regarding the coefficients of importance, the following limitation must be observed.

$$K_{ATC} + K_{loss} = 1 \quad (3)$$

This relationship indicates that the sum of the significance coefficients should be equal to 1. Also, by zeroing each of the coefficients of importance, the objective function practically acts in one part.

2.1.3. Constraints of Problems

Every optimization problem contains equality and inequality constraints. In this paper also the problem

contains different equality and inequality constraints. The problem constraints generally can be stated as follows:

$$\begin{aligned} g(x, u) &= 0 \\ h(x, u) &\leq 0 \end{aligned} \quad (5)$$

X: problem variables, u: problem inputs

The first part generally shows the limits of inequality and the second part shows the limits of equality.

2.1.3.1. Power Flow of Network

Network power flow is one of the problem equality constraints. To this end, each answer which is obtained for the problem should be true in the problem's power flow relations. Following relation indicates the way of modelling the relations (Zadehbagheri et al., 2023).

$$\begin{aligned} PG_i - PL_i &= \sum V_i V_j Y_{ij} \cos(\theta_{ij} + \delta_j - \delta_i) \\ QG_i - QL_i &= -\sum V_i V_j Y_{ij} \sin(\theta_{ij} + \delta_j - \delta_i) \end{aligned} \quad (6)$$

Where,

PG, QG: injection active and reactive power in terms of Pu
PL, QL: consumed active and reactive power in terms of Pu

The Newton-Raphson method is usually used to solve the load flow problem. This method is fully expressed in the references related to the study of power systems. The basis of this method is mathematical solution by gradient method (Ravi et al., 2013).

2.1.3.2. Voltage limitation of network buses

The operating conditions of each network must be such that the voltage at all points of the network is within the standard range. In each country, depending on the standard of that country, the upper and lower limits for voltage are determined. Usually the acceptable range for mains voltage [0.95 1.05] is equal to the nominal value. If the mains voltage is less or more than the allowable value, then several damages will be caused to the consumers in the network (Nasr Azadani et al., 2008).

$$V_{Li}^{\min} \leq V_{Li} \leq V_{Li}^{\max} \quad (7)$$

Where,

V_{Li} : Bus Voltage, i

V_{Li}^{\min} : The lowest allowable voltage in the network

V_{Li}^{\max} : The maximum allowable voltage in the network

2.1.3.3. Limitation of power passing through network lines

Grid lines have thermal limitations. According to this limitation, if the current passing through the transmission lines exceeds a certain limit, these lines will be in a critical state. The following equation shows how to model line capacity constraints (Canizares et al., 2003).

$$\begin{aligned} S_{ij} &\leq \eta S_{ij}^{\max} \\ S_{ij} &= |V_i I_{ij}^*| \\ I_{ij} &= (V_i - V_j) Y_{ij} \\ \eta &\leq 1 \\ \eta &: \text{Lines security margin} \end{aligned} \quad (8)$$

In practice, due to security issues, a percentage of transmission capacity is usually considered as a margin of confidence. Therefore, the η value is usually considered to be about 0.8.

3. Model of FACTS Devices used in the paper

As mentioned before, in this research, three types of FACTS devices are used. The following is the mathematical model used for this equipment. In this research, the models used are static models and the dynamic effects of this equipment on the transmission network are not considered (Pishavaei et al., 2017).

3.1. Model of UPFC

In UPFC uses controllable Thyristors for control of injectable reactive power. Figure 1 shows the general diagram of the UPFC (Vijyakumar et al., 2008).

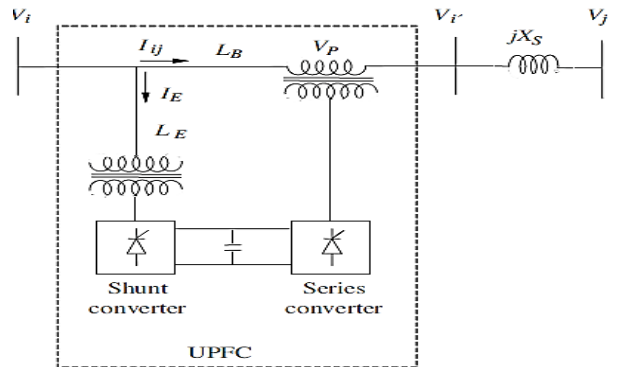

Fig.1. General diagram of UPFC

Mathematical relations governing injection power of UPFC to the network are as follows:

$$\begin{aligned} P_{ss} &= -b_s r V_i V_j \sin(\theta_i - \theta_j + \gamma) \\ Q_{ss} &= -b_s r V_i^2 (k + 2 \cos(\gamma)) + b_s r V_i V_j \cos(\theta_i - \theta_j + \gamma) \\ P_{sr} &= -P_{ss} \\ Q_{sr} &= b_s r V_i V_j \cos(\theta_i - \theta_j + \gamma) \end{aligned} \quad (9)$$

Where,

P_{ss} : injection active power to first bus of installation location in terms of pu

b_s : Admittance of the line of installation location in terms of pu

V : Network voltage in terms of pu

θ : Line voltage angle in terms of radian

r, γ : Regulatory parameters of UPFC

As observed, UPFC affects relations of power flow in both installation location buses.

3.2. Model of STATCOM

STATCOM is a static synchronic generator which operates as compensator of parallel reactive power, and its output inductive or capacitive current can be controlled independent of the system AC voltage. Figure 2 indicates STATCOM Single-line diagram. As observed, this compensator is connected to the network in parallel (Bindeshwar et al., 2010).

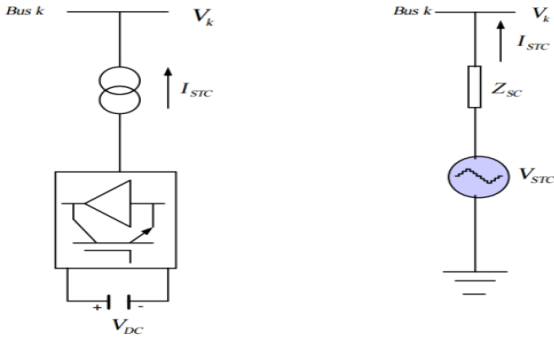

Fig. 2. Single line diagram of STATCOM.

Following relations indicate injection active and reactive power in the installation location of STATCOM.

$$\begin{aligned}
 P_{STC} &= G_{SC} \left\{ (e_{STC}^2 + f_{STC}^2) - (e_{STC}e_k + f_{STC}f_k) \right\} \\
 &+ B_{SC} (e_{STC}f_k - f_{STC}e_k) \\
 Q_{STC} &= G_{SC} (e_{STC}e_k - f_{STC}e_k) + \\
 &B_{SC} (-e_{STC}^2 - f_{STC}^2 + e_{STC}e_k + f_{STC}f_k) \\
 P_k &= G_{SC} \left\{ e_k^2 + f_k^2 - (e_k e_{STC}) \right\} + \\
 &B_{SC} (e_k f_{STC} - f_k e_{STC}) \\
 Q_k &= G_{SC} \left\{ e_k f_{STC} - f_k e_{STC} \right\} + \\
 &B_{SC} \left\{ (e_k f_{STC} + f_k e_{STC}) - (e_k^2 + f_k^2) \right\}
 \end{aligned} \tag{10}$$

Where,

e : Real part of voltage

f : Imaginary part of voltage

G, B : admittance parameters of transmission line

3.3. Model of SSSC

SSSC is a static synchronic generator which operates as a series compensator without external electric energy source, and its output voltage has 90 degrees of phase difference with the line current. Controllable output voltage is independent of the line current and it is used for increasing or decreasing total voltage drop across line. Figure 3 indicates schematic of SSSC model (Besharat et al., 2008).

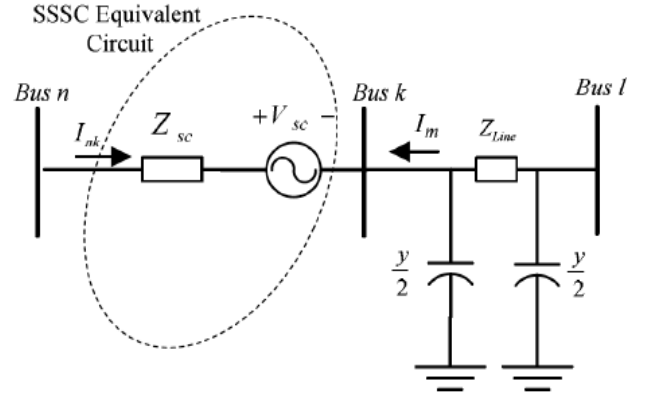

Fig. 3. SSSC model in transmission network.

Injection active and reactive power between buses of SSSC installation location is defined as follows:

$$\begin{aligned}
 P_{nl} &= (V_n^2 + V_{SC}^2) g_{nl} + 2V_n V_{SC} g_{nl} \cos(\varphi_{SC} - \delta_{nl}) \\
 &- V_n V_{SC} (g_{nl} \cos \varphi_{SC} + b_{nl} \sin \varphi_{SC}) \\
 Q_{nl} &= -V_n V_{SC} (g_{nl} \sin(\varphi_{SC} - \delta_{nl})) + b_{nl} \cos(\varphi_{SC} - \delta_{nl}) \\
 &- V_n^2 b_{nl} - V_n V_l (g_{nl} \sin \varphi_{SC} - b_{nl} \cos \varphi_{SC}) \\
 P_{ln} &= V_n^2 g_{nl} - V_l V_{SC} (g_{nl} \cos \varphi_{SC} - b_{nl} \sin \varphi_{SC}) \\
 &- V_n V_l (g_{nl} \cos \delta_{nl} - b_{nl} \sin \delta_{nl}) \\
 Q_{ln} &= -V_l^2 b_{nl} - V_l V_{SC} (g_{nl} \sin \varphi_{SC} - b_{nl} \cos \varphi_{SC}) \\
 &+ V_n V_l (g_{nl} \sin \delta_{nl} + b_{nl} \cos \delta_{nl})
 \end{aligned} \tag{11}$$

Where,

g, b : Transmission line parameters

φ_{sc}, V_{sc} : SSSC control parameters

SSSC contains two control parameters, which these parameters should be true in the following constraints:

$$\begin{aligned}
 V_{SC}^{\min} &\leq V_{SC} \leq V_{SC}^{\max} \\
 0 &\leq \varphi_{SC} \leq 2\pi
 \end{aligned} \tag{12}$$

3.4. Calculating total transfer capacity (TTC)

There are different methods for calculating total transmission capacity in the network. In this paper, repeat power flow (RPF) method is used for calculating available transmission capacity. In RPF, the power and generation is increased in the network for obtaining transmission

capacity in the network, and each time the network power flow is calculated. The process is stopped when one of the system's static constraints is violated, and TTC value is calculated as follows:

$$TTC = \sum_n^{\sum PD_i^0} PD_i^{max} \quad (13)$$

PD_i^{max} : Load value of bus i at the maximum loading point

PD_i^0 : Load value of bus i at the base mode

Thus maximum loading value in the network can be obtained. Of course it should be noted that it is highly dependent on the generation and consumption pattern in the network. In this method, power of all network's buses is increased in the same rate. Also generation in the network is also increased in the same rate. It is shown in the following relation (Movahedpour et al., 2022).

$$\begin{aligned} PD_i^k &= PD_i^0 \lambda^k \\ PG_i^k &= PG_i^0 \lambda^k \end{aligned} \quad (14)$$

K: Index related to the repetition of kth

λ^k : Multiplying the increase in load and generation in the repetition of kth

4. Harmony Search Algorithm (HSA)

In this paper, the main purpose is finding optimal location for installation of FACTS devices, thus the main variable of problem is optimal locating. Harmony search algorithm is taken from natural process of music implementation. The flowchart of HSA is shown in Figure 4. Overall an optimization problem by HSA algorithm is defined as follows:

$$\begin{aligned} \min f(X), X &= [X_1, \dots, X_n] \\ X_i &\in [LB_i, UB_i] \end{aligned} \quad (15)$$

Where,

N: Number of problem's variables

LB_i, UB_i : Lower and upper limits for variable X_i

The HSA algorithm has five general parameters as follows:

- Harmony Memory Size (HMS)
- Harmony Memory Considering Rate (HMCR)
- Pitch Adjusting Rate (PAR)
- Bandwidth (BW)
- Number Of Improvisations (NI)

Regulating these parameters is necessary for each problem. General steps of the algorithm are as follows:

a) Initializing the parameters:

In this step, the problem's variables are given value in their allowed limits randomly.

b) Algorithm memory formation:

In this step, a vector of the best available answer is stored in the algorithm memory.

$$HM = \begin{bmatrix} x^1 \\ x^2 \\ \vdots \\ x^1 \end{bmatrix} \quad (16)$$

c) Forming improved memory:

In this step, using x values in the algorithm memory, new values in terms of **PAR** parameter and a random part are obtained (Abdelaziz et al., 2009).

$$x_i' = \begin{cases} x_i' \in \{x_i^1, x_i^2, \dots, x_i^{HMS}\} & \text{with probability HMCR} \\ x_i' \in X_i & \text{with probability 1-HMCR} \end{cases} \quad (17)$$

HMCR: Probability of a variable entry to the new memory from previous memory

In the next step, obtained new vector is evaluated using **PAR** rate.

$$x_i' \leftarrow \begin{cases} \text{Yes with probability PAR} \\ \text{No with probability (1-PAR)} \end{cases} \quad (18)$$

If the above test returns no value for x_i' , x_i' value is entered the next step intact, but if the test result is **yes**, then its new value is obtained as follows:

$$\begin{aligned} x_i^{new} &= x_i^{old} + \alpha \\ \alpha &= bw * r \end{aligned} \quad (19)$$

bw: determined bandwidth for the algorithm.

r: Random value in interval [-1, 1].

In the next step, pitch adjusting rate is updated. It is shown by the following relation.

$$PAR = r_{accept} * r_{pa} \quad (20)$$

r_{pa} : Initial pitch rate

r_{accept} : Random value in interval [0, 1]

New algorithm memory is updated based on the best answers, and above steps are passed so that the iteration number of algorithm is ended (Movahedpour et al., 2022).

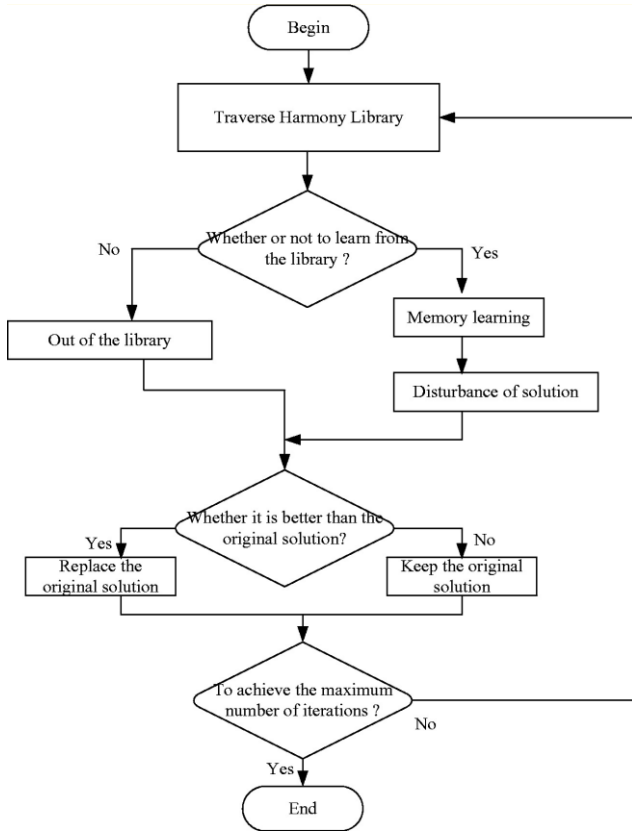

Fig.4. Flowchart of HSA algorithm

4.1 Problem Solving Using HSA

Harmony search algorithm is used to solve the optimization problem. The following relation shows the merit function of each response.

$$F = \left(K_{ATC} \frac{TTC_0}{TTC} + K_{loss} \frac{Loss}{Loss_0} \right) \cdot penalty_fact \quad (21)$$

To model the constraints in the problem, the method of penalty coefficients is used in the objective function. The following sets of relationships show how to model penalty coefficients for existing constraints (Naderi et al., 2019).

$$penalty_fact = e^{-it \cdot \alpha}$$

$$\alpha = \frac{c(x) + |c(x)|}{2} \quad :if \ c(x) \leq 0 \ (ineq \ constraint) \quad (22)$$

$$\alpha = |d(x)| \quad :if \ d(x) = 0 \ (eq \ constraint)$$

(it) is the coefficient of reducing the effect of constraints, which has a larger value in the initial iterations of the algorithm, and its value becomes smaller as the algorithm approaches the end of the iterations. In order for the algorithm not to deviate from its main goal, these coefficients are used to reduce the effect of constraints in the objective function. This coefficient takes a value in the interval [0, 1].

5. Numerical Studies

Numerical studies are done on modified network IEEE 30-BUS and IEEE 118-BUS. Figure 5 indicates single-line diagram of this network (Afkousi et al., 2010).

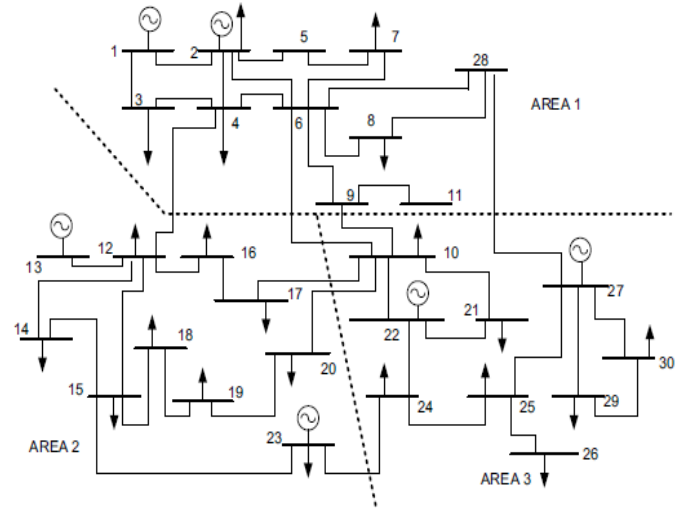

Fig. 5. Single-line diagram of network IEEE 30-BUS

This network contains 6 generators and 41 transmission lines. Network load is considered as 283,4 MW at nominal working point. Table 1 (Appendix) gives characteristics of network transmission lines. In this table transmission line parameters are given in terms of P.u. in 100 MVA unit. Also P_{MAX} (capacity of every line) is stated in terms of MW. Table 2 (Appendix) gives characteristics of network loads in different points. Values in this table are in terms of MW.

5.1 Primary studies without the presence of the FACTS devices

In this case, initial studies are done without installing FACTS devices in the network. For this purpose, using the Newton-Raphson method, network load flow is solved. In the initial studies, the issues that are important are the amount of network losses and the amount of transfer capability of the entire network. In the following sections, these values are compared with similar values in the following sections. After preliminary studies, it is determined that the value of TTC for the network is 61.1745 MW. It means that with the existing conditions, a maximum of 61.2 MW more power can be transmitted in the network. If the network load exceeds this value, then one or more constraints in the network will be violated. Also, the amount of network losses is 9.6 MW in the basic state. Figure 6 shows the network voltage before installing FACTS devices. As you can see, the network voltage has a big drop in some places. For example, in Bus 5, the network voltage is less than 0.95. This shows that this bus is far away from the generators. Therefore, one of the weakest network buses is obtained in terms of voltage.

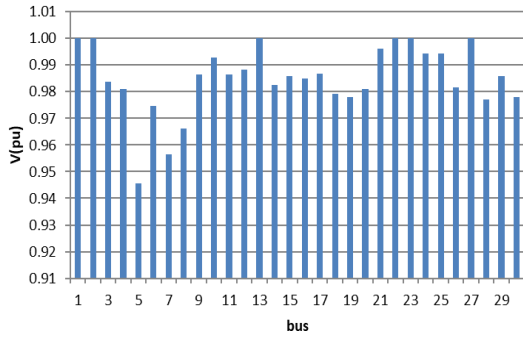

Fig. 6. Network voltage before installing FACTS devices (Without FACTS)

Figure 7 shows the loadability of network lines. As you can see, the network lines have different loadability in different sections. The beginning lines of the network are more productive than the end lines. Because a large part of the network load is supplied from the primary lines of the network.

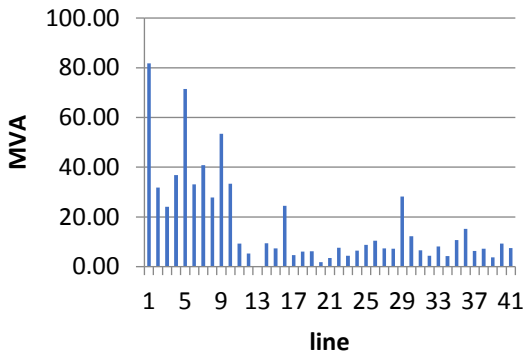

Fig. 7. Load ability network lines in initial mode (Without FACTS)

5.2 Solving the problem using FACTS devices

The problem is solved in the next section in four scenarios:
 Scenario 1: Using UPFC in network

Scenario 2: Using STATCOM in network

The results of the problem are obtained in each of the above sections and finally a comparison is made between the obtained results. For problem solving, HAS with following characteristics is used:

Table 3
 Characteristics of the algorithm used for problem solving

Iteration number	30
Memory	6
Minimum pitch rate	0.4
Maximum pitch rate	0.9
Minimum bandwidth	0.0001
Maximum bandwidth	1
Harmony Memory Considering	0.9

5.2.1. Solving the problem using a UPFC in the network

After solving the problem, the best place to install UPFC line 10-bus 6 is obtained. In this way, a UPFC is installed in the desired location. By installing this UPFC, the network loss value is 8.87 MW. This value is lower than the initial value in the network. The reason for that is the reactive compensation at the UPFC installation site. In fact, by supplying reactive power locally, UPFC has been able to reduce the flow of lines and therefore reduce losses. Also, the value of TTC for the network is 67.41 MW. This value is greater than the value obtained in the initial state. The results of this part show that the use of UPFC in the network has freed up the capacity of the network lines and therefore the network loadability has increased. Table 4 shows the results obtained in the first scenario.

Table 4
 Summary of the results obtained in the first scenario

Installation location	Number	r_{upfc}	r_{upfc}	γ_{upfc}	Network losses	TTC
Line 10-Bus 6	1	1	0.1	0.5236	8.87	67.41

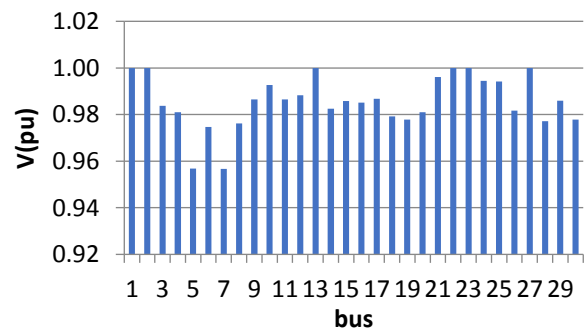

Fig. 8. Network buses voltage for 30- bus network

Figure 8 shows the voltage of the network buses. Comparison of this figure with the figure of the first scenario shows that a noticeable improvement can be seen in some of the network buses. Especially in the buses near the UPFC installation place, the voltage increase is fully observed. The voltage of all network buses is within the standard range.

5.2.2. Solving the problem using all three devices simultaneously

In this part, all three devices are used simultaneously in the network. The number of equipment in this section is also considered 1. In this section, it is assumed that the three devices are installed simultaneously. If the order of equipment installation is also considered, the results may change.

5.3 Comparison of the reviewed scenarios

Table 6 shows the optimal location obtained for the devices in different scenarios. As can be seen in the fourth scenario, only the installation location of the STATCOM has

changed. This shows that the installation of FACTS equipment changes the operation of the network.

Table 6
Optimal locations obtained in different scenarios

FACTS	UPFC	STATCOM	SSSC
Scenario 1	Line -10 Bus 6	*	*
Scenario 2	*	Bus 19	*

In the first scenario, the best location for UPFC installation is line 10 and bus 6. Since UPFC has series branch and a parallel branch, probably there would be capacity shortage problem in the line, and voltage drop may occur in the bus of installation location. The best location for STATCOM installation is bus 19. This bus in the poor situation in terms of voltage, and thus it is selected as the best location for installation. It is also observed that the best location for SSSC installation is line 35 and bus 25. In the fourth scenario it is observed that location for UPFC installation has been changed. It indicates that using three devices simultaneously provides different response compared to single use of devices. It is due to impact of installed devices on the network function. Table 7 shows the amount of losses and transmission capacity in the reviewed scenarios. It can be seen that in all scenarios, the amount of losses has decreased, and transmission line capacity is increase. It denotes that FACTS devices have significant impact on loss reduction and increasing total transfer capacity.

Table 7
Amount of losses and TTC after solving the problem

Scenarios	Losses	TTC
Base mode	9.6021	61.0745
Scenario 1	8.8659	67.4054
Scenario 2	8.7077	64.3841

Figure 9 shows the comparison of loss reduction in the examined scenarios compared to the base mode. In this figure, it is clear that the amount of losses in the fourth scenario has decreased more than other scenarios. In this section, three devices are used simultaneously. Also, the installation of UPFC had less impact on reducing losses.

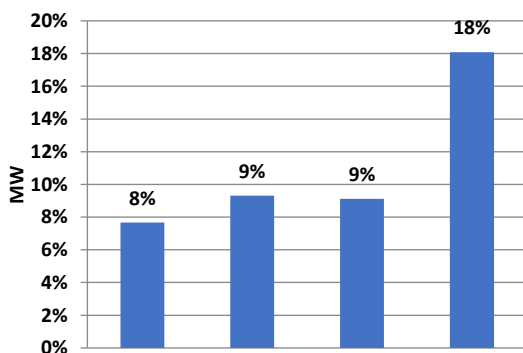

Fig. 9. The rate of losses reduction in different scenarios

Figure 10 shows the network voltage in this section. In this figure it is observed that network transmission capability is increased more in fourth scenario than other scenarios. The installation of UPFC had a greater effect on increasing the transmission capability. Comparing the results of this section with the amount of losses in the previous figure shows that the series branch in UPFC had a greater effect on the release of line capacity. The use of STATCOM has had less impact on the transmission capability of the lines. Due to the fact that STATCOM is a parallel device and does not have a series branch, its effect on releasing the capacity of the lines has been low. The comparison of the results of this section shows that most of the devices with series branches have a greater impact on the release of line capacity.

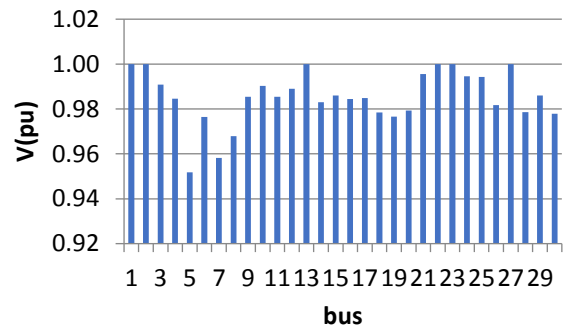

Fig. 10. Network voltage by installing SSSC in the network

Figure 11 shows the process of increasing transfer capacity during problem solving. It can be seen that in all scenarios, transfer capacity has gradually increased during the solution of the problem. Finally, it is clear that in the fourth scenario, the transfer capacity value has converged to a higher number.

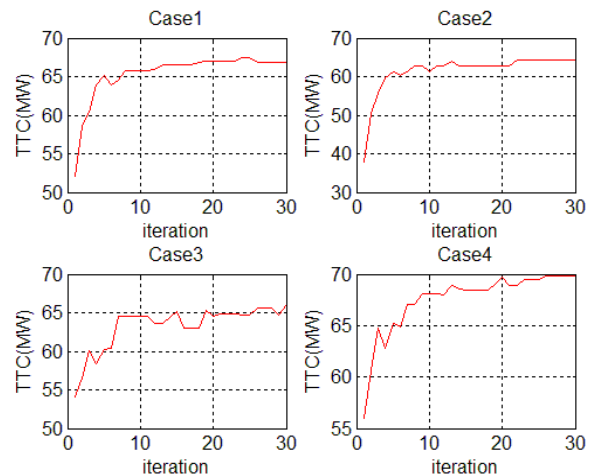

Fig. 11. TTC increase trend during problem solving in different scenarios

Figure 12 shows the trend of loss reduction during problem solving. In this figure it is evident that network losses has decreasing trend during problem solving. This process is very fast at the beginning of the iterations, but gradually the speed of loss reduction decreases and finally the algorithm converges to a single answer. The amount of loss reduction in the fourth scenario has converged to a lower value than other scenarios.

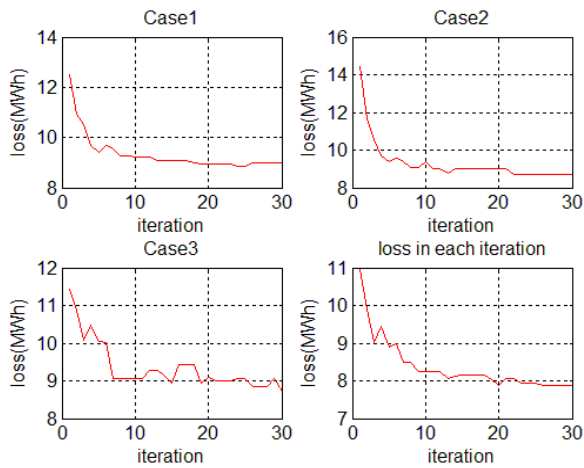

Fig. 12. Trend of losses reduction during problem solving

6. Conclusion

In this paper, the main objective was to determine the location and parameters of FACTS devices in transmission networks with the aim of reducing losses and increasing the TTC. For this purpose, the Intelligent HSA optimization algorithm has been used. Numerical studies have been carried out in 4 different scenarios and in two general sections on two typical IEEE 30-Bus and IEEE networks. The results obtained in the numerical studies section show that in general, FACTS devices in the network can reduce losses and increase the TTC. But the noteworthy point is that using FACTS devices in combination can have a better effect on network efficiency. In fact, the use of devices with series and parallel branches in a combined manner has a good effect on the network operation. Comparing the results shows that UPFC installation had a greater effect on increasing transmission capability. The series branch in UPFC had a greater effect on line capacity release.

References

Abdelaziz L., & Mohamed Boudour., (2009), "Optimal Location of SVC for Voltage Security Enhancement using MOPSO". Journal of electrical systems, Special Issue No.1, 73-78.

Afkousi-Paqaleh, M., Rashidinejad, M., & Pourakbari-Kasmaei, M. (2010). An implementation of harmony search algorithm to unit commitment problem. Electrical Engineering, 92, 215-225.

Avinash. R, Savyasachi. G. K, Gowtham. N, Rakshith. P, (2015) "Optimal Location of STATCOMS using FVSI" International Advanced Research Journal in Science, Engineering and Technology Vol. 2, Issue 6,

Azadani, E. N., Hosseinian, S. H., & Hasanpor, P. (2008). Optimal placement of multiple STATCOM for voltage stability margin enhancement using particle swarm optimization. Electrical Engineering, 90, 503-510.

Baghaee, B. Vahidi, S. Jazebi, G. B. Gharehpetian and A. Kashefi, (2008). Power System Security Improvement by Using Differential Evolution Algorithm Based FACTS Allocation. Joint International Conference on

Power System Technology and IEEE Power India Conference, New Delhi, India, pp. 1-6.

Besharat, H., & Taher, S. A. (2008). Congestion management by determining optimal location of TCSC in deregulated power systems. International Journal of Electrical Power & Energy Systems, 30(10), 563-568.

Bindeshwar Singh.; Sharma, N. K.; and Tiwari, A.N. (2010), "Prevention of Voltage Instability by Using FACTS Controllers in power systems": a literature survey. International Journal of Engineering Science and Technology, 2(5), 980-992.

Canizares, C. A., Pozzi, M. Corsi S. & Uzunovic, E. (2003) "STATCOM modeling for voltage and angle stability studies," Elect. Power and Energy Syst., vol. 25, pp. 431-441, 2003.

El Metwally M. M., El Emrly A.A., El Bendary F. M., & Mosaad M.I., (2008). Optimal Allocation of FACTS Devices in Power System Using Genetic Algorithms., IEEE Trans.

Esmaili, H., Ramezani, Y., & Hemmatyar, A. M. A. (2012). ATC enhancement using SSSC, a case study of harmony search vs PSO. J. Basic Appl. Sci. Res, 2, 3416-3425.

Gaur, D., & Mathew, L. (2018). Optimal placement of FACTS devices using optimization techniques: A review. In IOP Conference series: materials science and engineering (Vol. 331, No. 1, p. 012023). IOP Publishing.

Ildarabadi, R, Nejad, M. B., & Sutikno, T. (2017). A new structure of dynamic voltage restorer based on asymmetrical γ -source inverters to compensate voltage disturbances in power distribution networks. International Journal of Power Electronics and Drive Systems, 8(1), 344.

Irshad, H. Ullah, I., Ali, W., Muhammad, G., & Ali, Z. (2022). Exploiting lion optimization algorithm for sustainable energy management system in industrial applications. Sustainable Energy Technologies and Assessments 52: 102237.

Javadian, A., Zadehbagheri, M., Kiani, M. J., Nejatian, S., & Sutikno, T. (2021). Modeling of static var compensator-high voltage direct current to provide power and improve voltage profile. International Journal of Power Electronics and Drive Systems (IJPEDS), 12(3), 1659-1672.

Jordehi AR, Joorabian M. (2011). Optimal placement of Multi-type FACTS devices in power systems using evolution strategies. In: Power engineering and optimization conference (PEOCO), 2011 5th international: IEEE; 2011. p.352-7.

Kavitha, K., & Neela, R. (2016). Comparison of BBO, WIPSO & PSO techniques for the optimal placement of FACTS devices to enhance system security. Procedia Technology, 25, 824-837.

Kiani, M, et al. (2023), A new method for online evaluation of the effects of PV panels and comparison with MVDI in electrical power distribution networks. Renewable Energy Focus, 44, 106-123.

- Kowsalaya, M. K., Ray K. & Kothari D. P. (2008). Voltage Stability Enhancement Through Optimal Location of Var Compensator", ICSET, 2008.
- Lashkar Ara, A., Rahmani, A. H., Parham, E. & Behshad, M. (2012) "multi-objective dynamic optimal power flow through the ϵ -constraint method with non-smooth and non-convex fuel cost functions", Energy Education Science and Technology Part A: Energy Science and Research 2012 Volume (issues) 29(2): 1003-1014.
- Malakar, T.; Sinha, N.; Goswami, S. K.; and Saikia, L. C., (2010). "Optimal Location and Size Determination of FACTS Devices by using Multiobjective Optimal Power Flow", TENCON, 474-478.
- Movahedpour, M., Kiani, M. J., Zadehbagheri, M., & Mohammadi, S. (2022). Microgrids operation by considering demand response and supply programs in the presence of IGDT-based reverse risk. IEEE Access, 10, 48681-48700.
- Naderi, E., Pourakbari-Kasmaei, M., & Abdi, H. (2019). An efficient particle swarm optimization algorithm to solve optimal power flow problem integrated with FACTS devices. Applied Soft Computing, 80, 243-262.
- Nguimfack-Ndongmo JdD, Kenné G, Kuate-Fochie R, Cheukem A, Fotsin HB, Lamnabhi-Lagarriague F. A. (2009) simplified nonlinear controller for transient stability enhancement of multimachine power systems using SSSC device. Int J Electr Power Energy Syst 2014; 54:650–7. Del Valle YE. Optimization of power system performance using facts devices, PhD dissertation, Georgia Institute of technology.
- Phadke, A. R., Fozdar, M. Niazi, K. R. (2012) "A new multi-objective fuzzy-GA formulation for optimal placement and sizing of shunt FACTS controller", Applied Energy 40, 46-53
- Pishavaei, M., Ildarabadi, R., & Sutikno, T. (2017). The coordinated control of FACTS and HVDC using H-infinity robust method to stabilize the inter-regional oscillations in power systems. Int. J. Power Electron. Drive Syst, 8(3), 1274-1284.
- Rahimzadeh, S., & Bina, M. T. (2011). Looking for optimal number and placement of FACTS devices to manage the transmission congestion. Energy conversion and management, 52(1), 437-446.
- Rahmani, E., Mohammadi, S., Zadehbagheri, M., & Kiani, M. (2023). Probabilistic reliability management of energy storage systems in connected/islanding microgrids with renewable energy. Electric Power Systems Research, 214, 108891.
- Rashed, G. I., Sun, Y., & Shaheen, H. I. (2012). Optimal location and parameter setting of TCSC for loss minimization based on differential evolution and genetic algorithm. Physics Procedia, 33, 1864-1878.
- Ravi, K., & Rajaram, M. (2013). Optimal location of FACTS devices using improved particle swarm optimization. International Journal of Electrical Power & Energy Systems, 49, 333-338.
- Shaheen, H. I.; Rashed, G. I.; & Cheng, S. J., (2008), "Optimal Location and Parameters Setting of UPFC based on GA and PSO for Enhancing Power System Security Under Single Contingencies". IEEE Proc., Power and Energy society General Meeting Conversion and Delivery of Electrical Energy in the 21st Century.
- Sharma A, Chanana S, Parida S. (2005). Combined optimal located of FACTS controllers and loadability enhancement in competitive electricity markets using MILP. In: IEEE power engineering society general meeting (IEEE ESGM 2005), San Francisco, California, USA; 12–16 June 2005. p. 670–7.
- Shintemirov, A., W. J. Tang, W. J., Tang, W. H. & Wu Q.H. (2010). Improved modelling of power transformer winding using bacterial swarming algorithm and frequency response analysis, Electric Power Systems Research, vol. 80, pp. 1111–1120.
- Vijyakumar K. & Kumudinidevi R.P., (2008) "A Hybrid Genetic Algorithm for Optimal Power Flow Incorporating FACTS Devices", Asian Journal of Scientific Research, pp. 403-411.
- Zadehbagheri, M., Ildarabadi, R., & majid Javadian, A. (2023). Optimal Power Flow in the Presence of HVDC Lines Along with Optimal Placement of FACTS in order to Power System Stability Improvement in Different Conditions: Technical and Economic Approach. IEEE Access.
- Zadehbagheri, M, Payedar, A. (2015). "The feasibility study of using space vector modulation inverters in two-level of integrated photovoltaic system". TELKOMNIKA Indonesian Journal of Electrical Engineering, 14(2), 205-214.
- Zadehbagheri, M., Ildarabadi, R., & Sutikno, T. (2023). A unified power flow controller-based robust damping controller considering time delay in electrical power systems. Indonesian Journal of Electrical Engineering and Computer Science, 31(3), 1295-1310.